

# TABLE OF CONTENTS

<b>1.0</b>	<b>INTRODUCTION</b>	<b>1</b>
1.1	SYSTEM COVERAGE	1
1.2	SIX-STEP TROUBLESHOOTING PROCEDURE	1
<b>2.0</b>	<b>IDENTIFICATION OF SYSTEM</b>	<b>1</b>
<b>3.0</b>	<b>SYSTEM DESCRIPTION AND FUNCTIONAL OPERATION</b>	<b>1</b>
3.1	TEVES MARK 25e SYSTEM DESCRIPTION	1
3.2	TRACTION CONTROL SYSTEM (TCS) DESCRIPTION (IF EQUIPPED)	1
3.3	SYSTEM COMPONENTS	1
3.3.1	ABS AND BRAKE WARNING INDICATORS	2
3.3.2	ANTI-LOCK BRAKE MODULE	2
3.3.3	HYDRAULIC CONTROL UNIT	2
3.3.4	ABS SWITCHES/SENSORS	3
3.3.5	ABS INITIALIZATION	3
3.3.6	ABS DIAGNOSTIC MODE	3
3.3.7	TRACTION CONTROL OPERATION (IF EQUIPPED)	4
3.5	DIAGNOSTIC TROUBLE CODES	4
3.6	FREEZE FRAME	4
3.7	DRBIII® ERROR MESSAGES AND BLANK SCREEN	4
3.7.1	DRBIII® DOES NOT POWER UP	4
3.7.2	DISPLAY IS NOT VISIBLE	4
<b>4.0</b>	<b>DISCLAIMERS, SAFETY, WARNINGS</b>	<b>5</b>
4.1	DISCLAIMERS	5
4.2	SAFETY	5
4.2.1	TECHNICIAN SAFETY INFORMATION	5
4.2.2	VEHICLE PREPARATION FOR TESTING	5
4.2.3	SERVICING SUB-ASSEMBLIES	5
4.2.4	DRBIII® SAFETY INFORMATION	5
4.3	WARNINGS	6
4.3.1	VEHICLE DAMAGE WARNINGS	6
4.3.2	ROAD TESTING A COMPLAINT VEHICLE	6
4.4	DIAGNOSIS	6
<b>5.0</b>	<b>REQUIRED TOOLS AND EQUIPMENT</b>	<b>6</b>
<b>6.0</b>	<b>GLOSSARY OF TERMS</b>	<b>7</b>
<b>7.0</b>	<b>DIAGNOSTIC INFORMATION AND PROCEDURES</b>	<b>9</b>
	<b>BRAKES (25E)</b>	
	ABM INTERNAL	10
	BATTERY VOLTAGE OUT OF RANGE	12
	BCM MESSAGES NOT RECEIVED	14
	INSTRUMENT CLUSTER BULB	15
	LEFT FRONT WHEEL SPEED SENSOR CIRCUIT	17
	LEFT REAR WHEEL SPEED SENSOR CIRCUIT	17
	RIGHT FRONT WHEEL SPEED SENSOR CIRCUIT	17
	RIGHT REAR WHEEL SPEED SENSOR CIRCUIT	17
	LEFT FRONT WHEEL SPEED SENSOR SIGNAL	22

## TABLE OF CONTENTS - Continued

LEFT REAR WHEEL SPEED SENSOR SIGNAL .....	.22
RIGHT FRONT WHEEL SPEED SENSOR SIGNAL.....	.22
RIGHT REAR WHEEL SPEED SENSOR SIGNAL .....	.22
MIC MESSAGES NOT RECEIVED .....	.25
PCI BUS COMMUNICATION .....	.27
PCI BUS LOOPBACK.....	.30
PCI BUS SHORTED TO GROUND .....	.32
PCI BUS SHORTED TO VOLTAGE .....	.35
PCI HARDWARE.....	.38
PCM MESSAGES NOT RECEIVED.....	.40
PUMP MOTOR CIRCUIT .....	.42
TCM MESSAGES NOT RECEIVED.....	.44
<b>VERIFICATION TESTS</b>	
VERIFICATION TESTS.....	.45
<b>8.0 COMPONENT LOCATIONS.....</b>	<b>.47</b>
<b>8.1 DATA LINK CONNECTOR .....</b>	<b>.47</b>
<b>8.2 FUSES.....</b>	<b>.47</b>
<b>8.3 TRACTION CONTROL SWITCH .....</b>	<b>.47</b>
<b>8.4 INDICATORS.....</b>	<b>.48</b>
<b>8.5 BRAKE LAMP SWITCH .....</b>	<b>.48</b>
<b>9.0 CONNECTOR PINOUTS .....</b>	<b>.49</b>
ANTI-LOCK BRAKE MODULE - BLACK 47 WAY.....	.49
BRAKE LAMP SWITCH - BLACK 6 WAY .....	.50
DATA LINK CONNECTOR - BLACK 16 WAY .....	.50
FUSES (IPM).....	.52
WHEEL SPEED SENSOR-LEFT FRONT - LT. GRAY 2 WAY .....	.53
WHEEL SPEED SENSOR-LEFT REAR - LT. GRAY 2 WAY.....	.53
WHEEL SPEED SENSOR-RIGHT FRONT - LT. GRAY 2 WAY .....	.53
WHEEL SPEED SENSOR-RIGHT REAR - LT. GRAY 2 WAY .....	.54
<b>10.0 SCHEMATIC DIAGRAMS.....</b>	<b>.55</b>
<b>10.1 TEVES MARK 25e ANTI-LOCK BRAKE MODULE.....</b>	<b>.55</b>

## 1.0 INTRODUCTION

The procedures contained in this manual include all the specifications, instructions, and graphics needed to diagnose the Mark 25e Antilock Braking System (ABS). The diagnostics in this manual are based on the failure condition or symptom being present at time of diagnosis.

Please follow the recommendations below when choosing your diagnostic path.

1. First make sure the DRBIII® is communicating with the Anti-Lock Brake Module (ABM). If the DRBIII® displays a "No Response" condition, you must diagnose that first.
2. Read and record DTC's (diagnostic trouble codes) and Freeze Frame information with the DRBIII®.
3. If no DTC's are present, identify the customer complaint.
4. Once the DTC or customer complaint is identified, locate the matching test in the Table of Contents and begin to diagnose the symptom.

All component location views are in Section 8.0. All connector pinouts are in Section 9.0. All schematics are in Section 10.0.

An asterisk (\*) placed before the symptom description indicates a concern with no associated DTC.

When repairs are required, refer to the appropriate service manual for the proper removal and repair procedure.

Diagnostic procedures change every year. New diagnostic systems may be added; carry over systems may be enhanced. **READ THIS MANUAL BEFORE TRYING TO DIAGNOSE A VEHICLE CODE.** It is recommended that you review the entire manual to become familiar with all new and changed diagnostic procedures.

After using this book, if you have any comments or recommendations, please fill out the form at the back of the book and mail it back to us.

### 1.1 SYSTEM COVERAGE

This diagnostic procedure manual covers the Teves Mark 25e Antilock Braking System (ABS) found on the 2005 (CS) Pacifica.

### 1.2 SIX-STEP TROUBLESHOOTING PROCEDURE

Diagnosis of the ABM is done in six basic steps:

- verification of complaint
- verification of any related symptoms
- symptom analysis
- problem isolation

- repair of isolated problem
- verification of proper operation

## 2.0 IDENTIFICATION OF SYSTEM

Vehicles equipped with the Teves Mark 25e antilock brake system can be identified by the presence of the antilock brake module with a 47-way connector.

The presence of the Traction Control system is indicated by the switch and bulb check.

## 3.0 SYSTEM DESCRIPTION AND FUNCTIONAL OPERATION

### 3.1 TEVES MARK 25e SYSTEM DESCRIPTION

The Antilock Brake Module (ABM) is used to monitor wheel speeds and to modulate (control) hydraulic pressure in each brake channel. The modulated hydraulic pressure is used to prevent wheel lock-up during braking.

The Teves Mark 25e system uses a diagonal split hydraulic brake system. In the standard brake mode the master cylinder primary circuit supplies pressure to the right front and left rear wheel brakes, and the secondary master cylinder circuit supplies pressure to the left front and right rear wheel brakes.

All vehicles equipped with ABS use Electronic Variable Brake Proportioning (EVPB) to balance front-to-rear braking when brakes are applied in the partial braking range.

### 3.2 TRACTION CONTROL SYSTEM (TCS) DESCRIPTION (IF EQUIPPED)

The main purpose of traction control is to reduce wheel slip and maintain traction at the driven wheels when road surfaces are slippery. The traction control system reduces wheel slip by braking the wheel that is losing traction. The system is designed to operate at speeds below 56 km/h (35 mph).

### 3.3 SYSTEM COMPONENTS

#### **ABS**

- anti-lock brake module (ABM)
- vacuum booster
- master cylinder

## GENERAL INFORMATION

---

- integrated hydraulic control unit (HCU), 1 pump motor.
- 4 wheel speed sensor/tone wheel assemblies
- ABS warning indicator
- fuses and wiring harness
- fluid reservoir
- brake lamp switch

### ABS With Traction Control

- ABM with Traction Control programming
- HCU with four additional control valves.
- TCS Switch
- TCS Indicator

### 3.3.1 ABS AND BRAKE WARNING INDICATORS

The amber ABS warning indicator is located in the instrument cluster. It is used to inform the driver that the antilock function has been turned off. The ABS warning indicator is controlled by the ABM. The ABM controls the lamp with a command over the PCI bus.

The ABS Warning Indicator will remain lit during every key cycle until a circuit or component fault is repaired and the ABM no longer detects the fault. After repair of a sensor signal fault or a pump motor fault, the ABM must sense all four wheels at 25 km/h (15 mph) before it will extinguish the ABS and TCS Indicator.

The Instrument Cluster will illuminate the ABS Warning Indicator if it loses communication with the ABM.

The red BRAKE warning indicator is also located in the instrument cluster. It can be activated in several ways. Application of the parking brake or a low fluid signal from the fluid level switch located in the master cylinder reservoir will cause the indicator to come on.

### 3.3.2 ANTI-LOCK BRAKE MODULE

The ABM is a microprocessor-based device that monitors wheel speeds and controls the antilock functions. The ABM contains two microprocessors that receive identical sensor signals and then independently process the information. The results are then compared to make sure that they agree. Otherwise, the ABM will turn off the antilock and turn on the ABS amber warning indicator.

The primary functions of the ABM are to:

- detect wheel locking tendencies
- control fluid pressure modulation to the brakes during antilock stop
- monitor the system for proper operation
- manage traction control functions

- provide communication to the DRBIII® while in diagnostic mode
- store diagnostic information in non-volatile memory

The ABM continuously monitors the speed of each wheel. When a wheel locking tendency is detected, the ABM will command the appropriate valve to modulate brake fluid pressure in its hydraulic unit. Brake pedal position is maintained during an antilock stop by being a closed system. The ABM continues to control pressure in individual hydraulic circuits until a wheel locking tendency is no longer present. The ABM turns on the pump motor during an antilock stop.

The antilock brake system is constantly monitored by the ABM for proper operation. If the ABM detects a system malfunction, it can disable the antilock system and turn on the ABS warning indicator. If the antilock function is disabled, the system will revert to standard base brake system operation.

The ABM inputs include the following:

- diagnostic communication
- four wheel speed sensors
- three power feeds: valve, pump, and microprocessor
- brake lamp switch
- traction control switch

The ABM outputs include the following:

- ABS warning indicator actuation
- 12 volts supply to wheel speed sensors
- valve actuation
- diagnostic communication
- PCI bus communication
- traction control lamp illumination

### 3.3.3 HYDRAULIC CONTROL UNIT

The hydraulic control unit (HCU) contains the valve block assembly, and pump/motor assembly. The HCU is attached to the ABM.

**Valve Block Assembly:** The valve block assembly contains valves with four inlet valves and four outlet valves. The inlet valves are spring-loaded in the open position and the outlet valves are spring loaded in the closed position. During an antilock stop, these valves are cycled to maintain the proper slip ratio for each wheel. If a wheel detects slip, the inlet valve is closed to prevent and further pressure increase. Then the outlet valve is opened to release the pressure to the accumulators until the wheel is no longer slipping. Once the wheel is no longer slipping, the outlet valve is closed and the inlet valve is opened to reapply pressure. If the wheel is decelerating within its predetermined limits (proper slip ratio), the inlet valve will close to hold

the pressure constant. On vehicles which are equipped with a traction control system, there are four additional valves, two isolate the master cylinder and two shuttle. During a traction control event the brakes are applied to reduce wheel slippage.

**Pump Motor Assembly:** The pump motor assembly provides the extra amount of fluid needed during antilock braking. The pump is supplied fluid that is released to the accumulators when the outlet valve is opened during an antilock stop. The pump is also used to drain the accumulator circuits after the antilock stop is complete. The pump is operated by an integral electric motor. This motor is controlled by the ABM. The ABM may turn on the pump motor when an antilock stop is detected. The pump continues to run during the antilock stop and is turned off after the stop is complete. Under some conditions, the pump motor will run to drain the accumulators during the next drive off. The ABM monitors the pump motor operation internally.

### 3.3.4 ABS SWITCHES/SENSORS

**Master Cylinder:** The master cylinder is a standard tandem compensating port design for ABS and non ABS systems. Traction control vehicles use a dual center port master cylinder. For proper traction control operation the standard master cylinder must not be used.

A fluid level switch is located in the master cylinder fluid reservoir. The switch closes when a low fluid level is detected. The fluid level switch turns on the brake warning indicator by grounding the indicator circuit. This switch does not disable the ABS system.

**Wheel Speed Sensors and Tone Wheels:** One active wheel speed sensor (WSS) is located at each wheel. The sensors use an electronic principle known as magneto-resistive to help increase performance, durability and low speed accuracy. The sensors convert wheel speed into a small digital signal. A toothed gear tone wheel serves as the trigger mechanism for each sensor.

The ABM sends 12 volts to power an Integrated Circuit (IC) in the sensor. The IC supplies a constant 7 mA signal to the ABM. The relationship of the tooth on the tone wheel to the permanent magnet in the sensor, signals the IC of the sensor to toggle a second 7 mA power supply on or off. The output of the sensor, sent to the ABM, is a DC voltage signal with changing voltage and current levels. The ABM monitors the changing amperage (digital signal) from each wheel speed sensor. The resulting signal is interpreted by the ABM as the wheel speed.

**Because of internal circuitry, correct wheel speed sensor function cannot be determined by a continuity or resistance check through the sensor.**

Correct antilock system operation is dependent on tone wheel speed signals from the wheel speed sensors. The vehicle's wheels and tires should all be the same size and type to generate accurate signals. In addition, the tires should be inflated to the recommended pressure for optimum system operation. Variation in wheel and tire size or significant variations in inflation pressure can produce inaccurate wheel speed signals; however, the system will continue to function when using the correct factory mini-spare.

### 3.3.5 ABS INITIALIZATION

System initialization starts when the key is turned to "run". At this point, the ABM performs a complete self-check of all electrical components in the antilock systems.

Between 8-17 km/h (5-10 mph), a dynamic test is performed. This will momentarily cycle the inlet and outlet valves, check wheel speed sensor circuitry, and run the pump motor at 25 km/h (15 mph). The ABM will try to test the pump motor. If the brake pedal is applied the test will be run at 40 km/h (24 mph) regardless of brake switch state. If, during the dynamic test, the brake pedal is applied, the driver may feel the test through brake pedal pulsations. This is a normal condition.

If any component exhibits a trouble condition during system initialization or dynamic check, the ABM will illuminate the ABS warning indicator and TCS Indicator, if equipped.

### 3.3.6 ABS DIAGNOSTIC MODE

To enter diagnostic mode, a vehicle speed must be below 10 km/h (6 mph) and no ABS condition present. If vehicle speed is not below 10 km/h (6 mph), a "No Response" message could be displayed by the DRBIII®. The following are characteristics of diagnostic mode:

- The amber ABS warning indicator will blink rapidly. If a hard trouble code, such as Battery Voltage Out of Range code is present, the indicator will be illuminated without blinking until the trouble condition is cleared.
- Antilock operation is disabled.
- The HCU valves cannot be actuated when the vehicle speed is above 8 km/h (5 mph). If valve actuation is attempted above 8 km/h (5 mph), a "No Response" message will be displayed on the DRBIII®.

## GENERAL INFORMATION

### 3.3.7 TRACTION CONTROL OPERATION (IF EQUIPPED)

The Anti-lock Brake Module (ABM) monitors wheel speeds. If, during acceleration, the module detects front (drive) wheel slip and the brakes are not applied, the ABM will enter traction control mode. Traction control works in the following order when drive wheel slip is detected.

1. Close the (normally open) isolation valves.
2. Start pump/motor and supply volume/pressure to front hydraulic circuits (pump runs continuously during traction control).
3. Open and close build and decay valves to maintain minimum wheel slip and maximum traction.

The cycling of the build and decay valves is similar to the ABS except that they work to control wheel spin by applying brakes. ABS function is to control wheel skid by releasing brakes.

Two pressure relief valves allow excess fluid volume to return to the reservoir when not used by the build/decay cycles. These are required because the pump supplies more volume than the traction control system requires.

If at any time the brake pedal is applied during a traction control cycle, the brake lamp switch will trigger the ABM to switch off the traction control.

The traction control system will be enabled at each ignition cycle. It may be turned off by depressing the Traction Control Switch. The traction control system function lamp will illuminate Traction Control immediately upon depressing the traction control switch button. The indicator will illuminate during a traction control event.

If the ABM calculates that the brake temperatures are high, the traction control system will become inoperative until a time-out period has elapsed. When in this thermal protection mode, the traction control indicator will illuminate; however, a fault will not be registered.

### 3.5 DIAGNOSTIC TROUBLE CODES

The Anti-lock Brake Module may report any of several Diagnostic Trouble Codes (DTC)s. For a list of DTC's diagnosed in this manual, refer to the Table of Contents.

### 3.6 FREEZE FRAME

Freeze Frame takes a "snapshot" of specific vehicle information the instant an ABS failure is recognized and stores this information into the ABM memory. This information can be accessed using the DRBIII® to help diagnose the fault. Freeze Frame

will capture the first time failure or only a new failure that occurs during the current ignition cycle.

### 3.7 DRBIII® ERROR MESSAGES AND BLANK SCREEN

Under normal operation, the DRBIII® will display one of only two error messages:

- User-Requested WARM Boot or User-Requested COLD Boot.

If the DRBIII® should display any other error message, record the entire display and call the STAR Center. This is a sample of such an error message display:

```
ver: 2.14
date: 26 Jul93
file: key_itf.cc
date: Jul 26 1993
line: 548
err: 0x1
User-Requested COLD boot
Press MORE to switch between this display
and the application screen.
Press F4 when done noting information.
```

#### 3.7.1 DRBIII® DOES NOT POWER UP

If the LED's do not light or no sound is emitted at start up, check for loose cable connections or a bad cable. Check the vehicle battery voltage (data link connector cavity 16). A minimum of 11 volts is required to adequately power the DRBIII®.

If all connections are proper and the vehicle battery is fully charged, an inoperative DRBIII® may be the result of faulty cable or vehicle wiring.

#### 3.7.2 DISPLAY IS NOT VISIBLE

Low temperatures will affect the visibility of the display. Adjust the contrast to compensate for this condition.

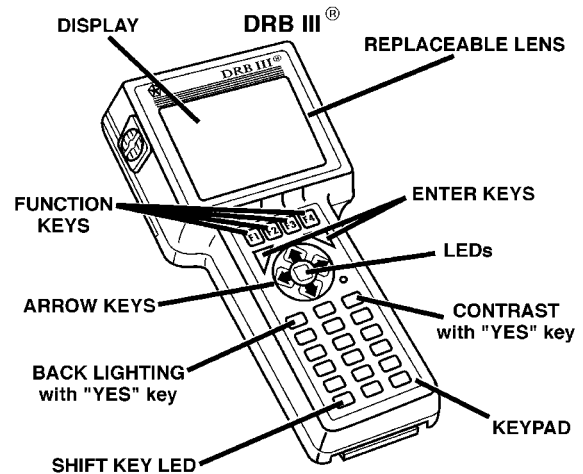

80b57566

## 4.0 DISCLAIMERS, SAFETY, WARNINGS

### 4.1 DISCLAIMERS

All information, illustrations, and specifications contained in this manual are based on the latest information available at the time of publication. The right is reserved to make changes at any time without notice.

### 4.2 SAFETY

#### 4.2.1 TECHNICIAN SAFETY INFORMATION

**WARNING: ENGINES PRODUCE CARBON MONOXIDE THAT IS ODORLESS, CAUSES SLOWER REACTION TIME, AND CAN LEAD TO SERIOUS INJURY. WHEN THE ENGINE IS OPERATING, KEEP SERVICE AREAS WELL VENTILATED OR ATTACH THE VEHICLE EXHAUST SYSTEM TO THE SHOP EXHAUST REMOVAL SYSTEM.**

Set the parking brake and block the wheels before testing or repairing the vehicle. It is especially important to block the wheels on front-wheel drive vehicles; the parking brake does not hold the drive wheels.

When servicing a vehicle, always wear eye protection, and remove any metal jewelry such as rings, watchbands or bracelets that might make an inadvertent electrical contact.

When diagnosing a chassis problem, it is important to follow approved procedures where applicable. These procedures can be found in the service manual. Following these procedures is very important to the safety of individuals performing diagnostic tests.

#### 4.2.2 VEHICLE PREPARATION FOR TESTING

Make sure the vehicle being tested has a fully charged battery. If it does not, false diagnostic codes or error messages may occur.

#### 4.2.3 SERVICING SUB-ASSEMBLIES

Some components of the chassis system are intended to be serviced as an assembly only. Attempting to remove or repair certain system sub-components may result in personal injury and/or improper system operation. Only those components with approved repair and installation procedures in the service manual should be serviced.

#### 4.2.4 DRBIII® SAFETY INFORMATION

**WARNING: EXCEEDING THE LIMITS OF THE DRBIII® MULTIMETER IS DANGEROUS. IT CAN EXPOSE YOU TO SERIOUS OR POSSIBLY FATAL INJURY. CAREFULLY READ AND UNDERSTAND THE CAUTIONS AND THE SPECIFICATION LIMITS.**

- Follow the vehicle manufacturer's service specifications at all times.
- Do not use the DRBIII® if it has been damaged.
- Do not use the test leads if the insulation is damaged or if metal is exposed.
- To avoid electrical shock, do not touch the test leads, tips, or the circuit being tested.
- Choose the proper range and functions for the measurement. Do not try voltage or current measurements that may exceed the rated capacity.
- Do not exceed the limits shown in the table below:

FUNCTION	INPUT LIMIT
Volts	0 - 500 peak volts AC 0 - 500 volts DC
Ohms (resistance)*	0 - 1.12 megohms
Frequency Measured Frequency Generated	0 - 10 kHz
Temperature	-58 - 1100°F -50 - 600°C

\* Ohms cannot be measured if voltage is present. Ohms can be measured only in a non-powered circuit.

- Voltage between any terminal and ground must not exceed 500v DC or 500v peak AC.
- Use caution when measuring voltage above 25v DC or 25v AC.
- Use the low current shunt to measure circuits up to 10A. Use the high current clamp to measure circuits exceeding 10A.
- When testing for the presence of voltage or current, make sure the meter is functioning correctly. Take a reading of a known voltage or current before accepting a zero reading.
- When measuring current, connect the meter in series with the load.
- Disconnect the live test lead before disconnecting the common test lead.
- When using the meter function, keep the DRBIII® away from spark plug or coil wires to avoid measuring error from outside interference.

## GENERAL INFORMATION

---

### 4.3 WARNINGS

#### 4.3.1 VEHICLE DAMAGE WARNINGS

Before disconnecting any control module, make sure the ignition is “off”. Failure to do so could damage the module.

When testing voltage or continuity at any control module, use the terminal side (not the wire end) of the connector. Do not probe a wire through the insulation, this will damage it and eventually cause it to fail because of corrosion.

Be careful when performing electrical tests so as to prevent accidental shorting of terminals. Such mistakes can damage fuses or components. Also, a second code could be set, making diagnosis of the original problem more difficult.

#### 4.3.2 ROAD TESTING A COMPLAINT VEHICLE

Some complaints will require a test drive as part of the repair verification procedure. The purpose of the test drive is to try to duplicate the diagnostic code or symptom condition.

**WARNING: BEFORE ROAD TESTING A VEHICLE, BE SURE THAT ALL COMPONENTS ARE REASSEMBLED. DURING THE TEST DRIVE, DO NOT TRY TO READ THE DRB SCREEN WHILE IN MOTION. DO NOT HANG THE DRBIII® FROM THE REAR VIEW MIRROR OR OPERATE IT YOURSELF. HAVE AN ASSISTANT AVAILABLE TO OPERATE THE DRBIII®.**

### 4.4 DIAGNOSIS

1. Your diagnostic test procedure must begin with a thorough visual inspection of the system in question for damaged components or disconnected connectors. For ABS the brake lamps must be operational prior to continuing.
2. Connect the DRBIII® to the data link connector, which is located under the dash to the left of the steering column. If the DRBIII® does not power up, check the power and ground supplies to the connector.
3. Turn the ignition on. Select the system in question. If the DRBIII® displays “No Response” condition you must diagnose that first.
4. Read and record all diagnostic trouble codes. For ABS if the “Battery Voltage Out of Range” diagnostic trouble code is present, it must be repaired prior to addressing any other DTC’s. If any additional DTC’s are present, proceed to the

appropriate test by locating the matching test in the Table of Contents and begin to diagnose the symptom.

5. For ABS if there are no diagnostic trouble codes present, identify the customer complaint. Select “Inputs/Outputs” and read the brake switch input as you press and release the brake pedal. If the display does not match the state of the pedal, diagnose the symptom. If a problem exists with the amber “ABS” warning indicator or the red “Brake” indicator exists, diagnose the symptom. Read the traction control switch input as you press and release the switch. If the display does not match the state of the indicator, diagnose the symptom.
6. If no other problems are found, it will be necessary to road test the vehicle. Perform several antilock stops from above 50 Km/h (30 mph) and then repeat step 4. If any diagnostic trouble codes are present, proceed to the appropriate test.
7. The following conditions should be considered “NORMAL” operation, and no repairs should be attempted to correct them.
  - Brake pedal feedback during an ABS stop (clicking, vibrating).
  - Clicking, groaning or buzzing at 25 Km/h (15 mph) or 40 Km/h (24 mph) (drive off self test).
  - Groaning noise during an ABS stop.
  - Slight brake pedal drop and pop noise when ignition is initially turned on.
  - Brake pedal ratcheting down at the end of an ABS stop.
8. If the complaint is ABS “cycling” at the end of a stop at low speeds, it may be caused by a marginal wheel speed sensor signal. The sensor air gap, tone wheel condition, and/or brakes hanging up are possible causes of this condition.
9. After a road test in which no problems were found, refer to any Technical Service Bulletins that may apply.

### 5.0 REQUIRED TOOLS AND EQUIPMENT

DRBIII® (diagnostic read-out box)  
jumper wires  
ohmmeter  
voltmeter  
test light



---

## 6.0 GLOSSARY OF TERMS

<b>ABM</b>	anti-lock brake module
<b>ABS</b>	antilock brake system
<b>BCM</b>	body control module
<b>DC</b>	direct current
<b>DLC</b>	data link connector
<b>DRB</b>	diagnostic read-out box
<b>DTC</b>	diagnostic test code
<b>EVBP</b>	electronic variable brake proportioning
<b>HCU</b>	hydraulic control unit
<b>I/C</b>	integrated circuit
<b>ICU</b>	integrated control unit
<b>IPM</b>	integrated power module
<b>JBLK</b>	junction block
<b>mA</b>	milli-Amp
<b>PCI</b>	programmable communication interface
<b>P/M</b>	pump motor
<b>TCS</b>	traction control system
<b>VSS</b>	vehicle speed signal
<b>WSS</b>	wheel speed sensor



---

7.0

DIAGNOSTIC INFORMATION AND  
PROCEDURES

**Symptom:**  
**ABM INTERNAL**

**When Monitored and Set Condition:**

**ABM INTERNAL**

When Monitored: Ignition On - Continuously

Set Condition: When one of two internal CPUs, fails the programmed self test within the ABM.

**POSSIBLE CAUSES**

INTERMITTENT DTC  
 DAMAGED ABM/ABM HARNESS CONNECTOR  
 FUSED RUN RELAY OUTPUT CIRCUIT OPEN  
 ABS VALVE FUSED B(+) CIRCUIT OPEN  
 ABS PUMP FUSED B(+) CIRCUIT OPEN  
 ABM - GROUND CIRCUIT OPEN  
 ABM - INTERNAL FAULT

TEST	ACTION	APPLICABILITY
1	Turn the ignition on. With the DRBIII®, read DTCs. With the DRBIII®, erase DTCs. Turn the ignition off. Turn the ignition on. With the DRBIII®, read DTCs. Does the DRBIII® display ABM INTERNAL?  Yes → Go To 2  No → Go To 7	All
2	Turn the ignition off. Disconnect the ABM harness connector. Inspect the ABM/ABM harness connector for damage. Is there any broken, bent, pushed out, corroded or spread terminals?  Yes → Repair as necessary. Perform ABS VERIFICATION TEST - VER 1.  No → Go To 3	All

**ABM INTERNAL — Continued**

TEST	ACTION	APPLICABILITY
3	Turn the ignition off. Disconnect the ABM harness connector. Turn the ignition on. Measure the voltage of the Fused Run Relay Output circuit. Is the voltage above 10 volts?  Yes → Go To 4  No → Repair the Fused Run Relay Output circuit for an open. Perform ABS VERIFICATION TEST - VER 1.	All
4	Turn the ignition off. Disconnect the ABM harness connector. Measure the voltage of the ABS Valve Fused B(+) circuit. Is the voltage above 10 volts?  Yes → Go To 5  No → Repair the ABS Valve Fused B(+) circuit for an open. Perform ABS VERIFICATION TEST - VER 1.	All
5	Turn the ignition off. Disconnect the ABM harness connector. Measure the voltage of the ABS Pump Fused B(+) circuit. Is the voltage above 10 volts?  Yes → Go To 6  No → Repair the ABS Pump Fused B(+) circuit for an open. Perform ABS VERIFICATION TEST - VER 1.	All
6	Turn the ignition off. Disconnect the ABM harness connector. Measure the resistance of the ground circuits. Is the resistance below 5.0 ohms?  Yes → Replace the Anti-Lock Brake Module in accordance with the Service Information. Perform ABS VERIFICATION TEST - VER 1.  No → Repair the ground circuit(s) for an open. Perform ABS VERIFICATION TEST - VER 1.	All
7	Turn the ignition off. Visually inspect the related wiring harness. Look for any chafed, pierced, pinched, or partially broken wires. Visually inspect the related wire harness connectors. Look for broken, bent, pushed out, or corroded terminals. Refer to any Hotline letters or Technical Service Bulletins that may apply. Were any problems found?  Yes → Repair as necessary. Perform ABS VERIFICATION TEST - VER 1.  No → Test Complete.	All

**Symptom:**  
**BATTERY VOLTAGE OUT OF RANGE**

**When Monitored and Set Condition:**

**BATTERY VOLTAGE OUT OF RANGE**

When Monitored: Ignition On - Continuously

Set Condition: When the ABM detects battery voltage out of specified range on the ABS Valve Fused B(+) circuit. Either the voltage is over 17.0 or under 7.5 volts on this circuit.

**POSSIBLE CAUSES**

INTERMITTENT DTC  
 BATTERY/CHARGING SYSTEM FAILURE  
 DAMAGED ABM/ABM HARNESS CONNECTOR  
 ABS VALVE FUSED B(+) CIRCUIT OPEN  
 GROUND CIRCUIT OPEN  
 ABM - INTERNAL FAULT

TEST	ACTION	APPLICABILITY
1	Turn the ignition on. With the DRBIII®, read DTC's. With the DRBIII®, erase DTC's. Turn the ignition off. Start the engine. With the DRBIII®, read DTC's. Does the DRBIII® display BATTERY VOLTAGE OUT OF RANGE?  Yes → Go To 2 No → Go To 6	All
2	Turn the ignition off. Perform a battery test and charging system test. <b>NOTE: Refer to service information for the related test(s)/symptom(s).</b> Does the battery and charging system pass?  Yes → Go To 3 No → Repair as necessary. Perform ABS VERIFICATION TEST - VER 1.	All
3	Turn the ignition off. Disconnect the ABM harness connector. Inspect the ABM and ABM harness connector for damage. Is there any broken, bent, pushed out, corroded or spread terminals?  Yes → Repair as necessary. Perform ABS VERIFICATION TEST - VER 1.  No → Go To 4	All

**BATTERY VOLTAGE OUT OF RANGE — Continued**

TEST	ACTION	APPLICABILITY
4	Turn the ignition off. Disconnect the ABM harness connector. Measure the voltage of the ABS Valve Fused B(+) circuit. Is the voltage above 10 volts?  Yes → Go To 5  No → Repair the ABS Valve Fused B(+) circuit for an open. If the fuse is open make sure to check for a short to ground. Perform ABS VERIFICATION TEST - VER 1.	All
5	Turn the ignition off. Disconnect the ABM harness connector. Measure the resistance of the ground circuits. Is the resistance below 5.0 ohms?  Yes → Replace the Anti-Lock Brake Module in accordance with the Service Information. Perform ABS VERIFICATION TEST - VER 1.  No → Repair the ground circuit(s) for an open. Perform ABS VERIFICATION TEST - VER 1.	All
6	Turn the ignition off. Visually inspect the related wiring harness. Look for any chafed, pierced, pinched, or partially broken wires. Visually inspect the related wire harness connectors. Look for broken, bent, pushed out, or corroded terminals. Refer to any Hotline letters or Technical Service Bulletins that may apply. Were any problems found?  Yes → Repair as necessary. Perform ABS VERIFICATION TEST - VER 1.  No → Test Complete.	All

**Symptom:**  
**BCM MESSAGES NOT RECEIVED**

**When Monitored and Set Condition:**

**BCM MESSAGES NOT RECEIVED**

When Monitored: Ignition On - Continuously

Set Condition: When the ABM detects the BCM is not connected or not functioning correctly for 10 seconds.

**POSSIBLE CAUSES**

ATTEMPT TO COMMUNICATE WITH THE BCM  
 BODY CONTROL MODULE

TEST	ACTION	APPLICABILITY
1	Turn the ignition on. With the DRBIII®, attempt to communicate with the Body Control Module. Was the DRBIII® able to I/D or communicate with the BCM?  Yes → Go To 2  No → Refer to the Communication category for the related symptom(s). Perform BODY VERIFICATION TEST - VER 1.	All
2	With the DRBIII®, erase DTC's. Cycle the ignition switch from off to on and wait approximately 1 minute. With the DRBIII®, read DTC's. Did this DTC reset?  Yes → Replace the Body Control Module in accordance with the service information. Perform BODY VERIFICATION TEST - VER 1.  No → Test Complete.	All



**Symptom:**  
**INSTRUMENT CLUSTER BULB**

**When Monitored and Set Condition:**

**INSTRUMENT CLUSTER BULB**

When Monitored: Ignition On - Continuously

Set Condition: When the mechanical instrument cluster informs the ABM that the ABS, Brake, and TCS (if equipped) indicators failed and can't be illuminated.

**POSSIBLE CAUSES**

INSTRUMENT CLUSTER OR ABM DTC PRESENT  
 CHECKING INSTRUMENT CLUSTER OPERATION  
 INSTRUMENT CLUSTER SELF-TEST  
 INSTRUMENT CLUSTER INTERNAL FAULT  
 ABM - INTERNAL FAULT

TEST	ACTION	APPLICABILITY
1	Turn the ignition on. With the DRBIII®, read DTCs. Are there any Instrument Cluster or ABM DTCs present?  Yes → Refer to the appropriate category for the related symptom(s). Perform ABS VERIFICATION TEST - VER 1.  No → Go To 2	All
2	Turn the ignition off. Perform the Key-on Bulb Check. Does the ABS, Brake, or TCS (if equipped) indicators light and then go out after four seconds?  Yes → Go To 3  No. Light remains after bulb check. Go To 4  No. Indicator never came on. Go To 5	All

**INSTRUMENT CLUSTER BULB — Continued**

TEST	ACTION	APPLICABILITY
3	Turn the ignition off. Turn the ignition on. With the DRBIII®, record and erase DTC's. <b>NOTE: If you have other DTCs, repair other DTCs first before continuing.</b> Turn the ignition off. Remove ABS Valve fuse. Perform the Key-on Bulb Check. Does the ABS, Brake, and TCS (if equipped) Indicators remain on after the 4 second bulb check?  Yes → Reinstall the ABS Valve fuse. With the DRBIII®, erase Instrument Cluster DTCs. Test Complete. Perform ABS VERIFICATION TEST - VER 1.  No → Go To 4	All
4	Reinstall the ABS Valve fuse, if removed. Turn the ignition off. Turn the ignition to RUN. Perform the Instrument Cluster self test. <b>NOTE: Refer to Body information for the related test(s).</b> Did the indicators illuminate during the Instrument Cluster self test?  Yes → Replace the Anti-Lock Brake module in accordance with the Service Information. Perform ABS VERIFICATION TEST - VER 1.  No → Go To 5	All
5	Turn the ignition off. Turn the ignition to RUN. Perform the Instrument Cluster self test. <b>NOTE: Refer to Body information for the related test(s).</b> Do the indicators turn on for 4 seconds, shut off for 5-10 seconds then illuminate?  Yes → Test Complete.  No → Ensure the ABS indicator bulb is installed or good in the Instrument Cluster. If verified working, replace the Instrument Cluster in accordance with the Service Information. Perform ABS VERIFICATION TEST - VER 1.	All

**Symptom List:**

**LEFT FRONT WHEEL SPEED SENSOR CIRCUIT**  
**LEFT REAR WHEEL SPEED SENSOR CIRCUIT**  
**RIGHT FRONT WHEEL SPEED SENSOR CIRCUIT**  
**RIGHT REAR WHEEL SPEED SENSOR CIRCUIT**

**Test Note: All symptoms listed above are diagnosed using the same tests. The title for the tests will be LEFT FRONT WHEEL SPEED SENSOR CIRCUIT.**

**When Monitored and Set Condition:****LEFT FRONT WHEEL SPEED SENSOR CIRCUIT**

When Monitored: Ignition On - Continuously

Set Condition: When the ABM detects a wheel speed sensor circuit current is out of range.

**LEFT REAR WHEEL SPEED SENSOR CIRCUIT**

When Monitored: Ignition On - Continuously

Set Condition: When the ABM detects a wheel speed sensor circuit current is out of range.

**RIGHT FRONT WHEEL SPEED SENSOR CIRCUIT**

When Monitored: Ignition On - Continuously

Set Condition: When the ABM detects a wheel speed sensor circuit current is out of range.

**RIGHT REAR WHEEL SPEED SENSOR CIRCUIT**

When Monitored: Ignition On - Continuously

Set Condition: When the ABM detects a wheel speed sensor circuit current is out of range.

**POSSIBLE CAUSES**

INTERMITTENT CONDITION

WHEEL SPEED SENSOR OR CONNECTOR DAMAGE

WHEEL SPEED SENSOR SIGNAL CIRCUIT FAULT

WHEEL SPEED SENSOR 12 VOLT SUPPLY CIRCUIT SHORT TO GROUND

WHEEL SPEED SENSOR 12 VOLT SUPPLY CIRCUIT OPEN

WHEEL SPEED SENSOR SIGNAL CIRCUIT SHORT TO GROUND

WHEEL SPEED SENSOR SIGNAL CIRCUIT OPEN

**LEFT FRONT WHEEL SPEED SENSOR CIRCUIT — Continued**

POSSIBLE CAUSES	
ABM - 12 VOLT SUPPLY CIRCUIT FAULT	
ABM - SIGNAL CIRCUIT FAULT	
WHEEL SPEED SENSOR 12 VOLT SUPPLY SHORT TO GROUND	
WHEEL SPEED SENSOR SIGNAL CIRCUIT INOPERATIVE	

TEST	ACTION	APPLICABILITY
1	Turn the ignition on. With the DRBIII®, read DTCs. With the DRBIII®, read and record Freeze Frame information. With the DRBIII®, erase DTCs. Turn the ignition off. Turn the ignition on. With the DRBIII®, read DTCs. <b>NOTE: The ABM must sense all four wheels at 25km/h (15 mph) before it will extinguish the ABS indicators.</b> Does the DRBIII® display WHEEL SPEED SENSOR CIRCUIT?  Yes → Go To 2  No → Go To 13	All
2	Turn the ignition off. Inspect the ABM connector, affected Wheel Speed Sensor, and affected Wheel Speed Sensor connector. Is the affected Wheel Speed Sensor or any of the connector(s) damaged?  Yes → Repair as necessary. Perform ABS VERIFICATION TEST - VER 1.  No → Go To 3	All
3	Turn the ignition off. Disconnect the affected Wheel Speed Sensor connector. <b>Note: Check connector - Clean/repair as necessary.</b> Turn the ignition on. Measure the voltage between affected Wheel Speed Sensor 12 Volt Supply circuit and ground. Is the voltage above 10 volts?  Yes → Go To 6  No → Go To 4	All
4	Turn the ignition off. Disconnect the ABM harness connector. Disconnect the affected Wheel Speed Sensor connector. Using a 12-volt test light connected to 12-volts, probe the affected Wheel Speed Sensor 12 Volt Supply circuit. Does the test light illuminate?  Yes → Repair the affected Wheel Speed Sensor 12 Volt Supply circuit for a short to ground. Perform ABS VERIFICATION TEST - VER 1.  No → Go To 5	All

**LEFT FRONT WHEEL SPEED SENSOR CIRCUIT — Continued**

TEST	ACTION	APPLICABILITY
5	Turn the ignition off. Disconnect the ABM harness connector. Disconnect the affected Wheel Speed Sensor connector. Connect a jumper wire between affected Wheel Speed Sensor 12 Volt Supply circuit and ground. Using a 12-volt test light connected to 12-volts, probe the affected Wheel Speed Sensor 12 Volt Supply circuit. Does the test light illuminate?  Yes → Go To 6  No → Repair the affected Wheel Speed Sensor 12 Volt Supply circuit for an open. Perform ABS VERIFICATION TEST - VER 1.	All
6	Turn the ignition off. Disconnect the affected Wheel Speed Sensor connector. <b>NOTE: Check connector - Clean/repair as necessary.</b> Turn the ignition on. Measure the voltage between affected Wheel Speed Sensor Signal circuit and ground. Is the voltage above 1 volt?  Yes → Repair the affected Wheel Speed Sensor Signal circuit for a short to voltage. Perform ABS VERIFICATION TEST - VER 1.  No → Go To 7	All
7	Turn the ignition off. Disconnect the ABM harness connector. Disconnect the affected Wheel Speed Sensor connector. Using a 12-volt test light connected to 12-volts, probe the affected Wheel Speed Sensor Signal circuit. Does the test light illuminate?  Yes → Repair the affected Wheel Speed Sensor Signal circuit for a short to ground. Perform ABS VERIFICATION TEST - VER 1.  No → Go To 8	All
8	Turn the ignition off. Disconnect the ABM harness connector. Disconnect the affected Wheel Speed Sensor connector. Connect a jumper wire between affected Wheel Speed Sensor Signal circuit and ground. Using a 12-volt test light connected to 12-volts, probe the affected Wheel Speed Sensor Signal circuit. Does the test light illuminate?  Yes → Go To 9  No → Repair the affected Wheel Speed Sensor Signal circuit for an open. Perform ABS VERIFICATION TEST - VER 1.	All

**LEFT FRONT WHEEL SPEED SENSOR CIRCUIT — Continued**

<b>TEST</b>	<b>ACTION</b>	<b>APPLICABILITY</b>
9	Turn the ignition off. Remove the ABM harness strain relief to access wires. Reconnect the ABM harness connector. Turn the ignition on. Measure the voltage between affected Wheel Speed Sensor 12 Volt Supply circuit and ground. Is the voltage above 10 volts? Yes → Go To 10 No → Replace the Anti-Lock Brake Module in accordance with the Service Information. Perform ABS VERIFICATION TEST - VER 1.	All
10	Turn the ignition off. Remove the ABM harness strain relief to access wires. Reconnect the ABM harness connector. Turn the ignition on. Measure the voltage between affected Wheel Speed Sensor 12 Volt Supply circuit and affected Wheel Speed Sensor Signal circuit. Is the voltage above 10 volts? Yes → Go To 11 No → Replace the Anti-Lock Brake Module in accordance with the Service Information. Perform ABS VERIFICATION TEST - VER 1.	All
11	Turn the ignition off. Reconnect ALL affected Wheel Speed Sensor circuit connectors. Disconnect the affected Wheel Speed Sensor connector. Turn the ignition on. Measure the voltage of the affected Wheel Speed Sensor 12 Volt Supply circuit in the affected Wheel Speed Sensor connector while reconnecting the sensor connector. Did the affected Wheel Speed Sensor 12 Volt Supply circuit drop voltage to 0 DC volts? Yes → Replace the affected Wheel Speed Sensor in accordance with the Service Information. Perform ABS VERIFICATION TEST - VER 1. No → Go To 12	All
12	Turn the ignition off. Reconnect ALL affected Wheel Speed Sensor circuit connectors. Turn the ignition on. Measure the DC voltage of the Wheel Speed Sensor Signal circuit in the affected Wheel Speed Sensor connector. Slowly rotate the wheel. Does the DC voltage toggle between 1.6 volts to .8 volts? Yes → Go To 13 No → Replace the affected Wheel Speed Sensor in accordance with the Service Information. Perform ABS VERIFICATION TEST - VER 1.	All

**LEFT FRONT WHEEL SPEED SENSOR CIRCUIT — Continued**

<b>TEST</b>	<b>ACTION</b>	<b>APPLICABILITY</b>
13	Turn the ignition off. Visually inspect the related wiring harness. Look for any chafed, pierced, pinched, or partially broken wires. Visually inspect the related wire harness connectors. Look for broken, bent, pushed out, or corroded terminals. Refer to any Hotline letters or Technical Service Bulletins that may apply. Were any problems found?  Yes → Repair as necessary. Perform ABS VERIFICATION TEST - VER 1.  No → Test Complete.	All

**Symptom List:**

**LEFT FRONT WHEEL SPEED SENSOR SIGNAL  
LEFT REAR WHEEL SPEED SENSOR SIGNAL  
RIGHT FRONT WHEEL SPEED SENSOR SIGNAL  
RIGHT REAR WHEEL SPEED SENSOR SIGNAL**

---

**Test Note: All symptoms listed above are diagnosed using the same tests.  
The title for the tests will be LEFT FRONT WHEEL SPEED  
SENSOR SIGNAL.**

---

**When Monitored and Set Condition:**

**LEFT FRONT WHEEL SPEED SENSOR SIGNAL**

When Monitored: Ignition On - Continuously

Set Condition: When the ABM detects the following on the wheel speed sensor signal circuit: missing signal, continuously low wheel speed, changes erratically, periodic drop out of a wheel speed, and too long of pressure reduction during an ABS event.

**LEFT REAR WHEEL SPEED SENSOR SIGNAL**

When Monitored: Ignition On - Continuously

Set Condition: When the ABM detects the following on the wheel speed sensor signal circuit: missing signal, continuously low wheel speed, changes erratically, periodic drop out of a wheel speed, and too long of pressure reduction during an ABS event.

**RIGHT FRONT WHEEL SPEED SENSOR SIGNAL**

When Monitored: Ignition On - Continuously

Set Condition: When the ABM detects the following on the wheel speed sensor signal circuit: missing signal, continuously low wheel speed, changes erratically, periodic drop out of a wheel speed, and too long of pressure reduction during an ABS event.

**RIGHT REAR WHEEL SPEED SENSOR SIGNAL**

When Monitored: Ignition On - Continuously

Set Condition: When the ABM detects the following on the wheel speed sensor signal circuit: missing signal, continuously low wheel speed, changes erratically, periodic drop out of a wheel speed, and too long of pressure reduction during an ABS event.

---

**POSSIBLE CAUSES**

WHEEL SPEED SENSOR SIGNAL DTC PRESENT  
AFFECTED WHEEL SPEED SENSOR SIGNAL INOPERATIVE  
AFFECTED WHEEL SPEED SENSOR CONNECTOR DAMAGED  
AFFECTED WHEEL SPEED SENSOR TONE WHEEL DAMAGED

---



**LEFT FRONT WHEEL SPEED SENSOR SIGNAL — Continued****POSSIBLE CAUSES**

AFFECTED WHEEL SPEED SENSOR AIR GAP FAULT  
 WHEEL BEARING FAULT  
 BRAKE LINING FAULT  
 AFFECTED WHEEL SPEED SENSOR CIRCUIT FAULT

TEST	ACTION	APPLICABILITY
1	Turn the ignition on. With the DRBIII®, read DTCs. With the DRBIII®, read and record Freeze Frame information. <b>NOTE: The ABM must sense ALL 4 wheels at 25 km/h (15 mph) before it will extinguish the ABS indicators.</b> Does the DRBIII® display WHEEL SPEED SENSOR SIGNAL and WHEEL SPEED SENSOR CIRCUIT?  Yes → Refer to the affected WHEEL SPEED SENSOR CIRCUIT for the related symptom(s). Perform ABS VERIFICATION TEST - VER 1.  No → Go To 2	All
2	Turn the ignition on. With the DRBIII® in Sensors, monitor ALL the Wheel Speed Sensor Signals while an assistant drives the vehicle. Slowly accelerate as straight as possible from a stop to 24 km/h (15 mph). Is the affected Wheel Speed Signal showing 0 km/h (0 mph)?  Yes → Go To 3  No → The condition is not present at this time. Monitor DRBIII® parameters while wiggling the related wiring harness. Refer to any Technical Service Bulletins(TSB) that may apply. Visually inspect the related wiring harness and connector terminals. Perform ABS VERIFICATION TEST - VER 1.	All
3	Turn the ignition off. Inspect the ABM connector, affected Wheel Speed Sensor, and affected Wheel Speed Sensor connector. Is the Wheel Speed Sensor or any connector damaged?  Yes → Repair as necessary. Perform ABS VERIFICATION TEST - VER 1.  No → Go To 4	All
4	Turn ignition off. Inspect the affected Tone Wheel for damaged, missing teeth, cracks, or looseness. <b>NOTE: The Tone Wheel teeth should be perfectly square, not bent, or nicked.</b> Is the affected Tone Wheel damaged?  Yes → Replace the Tone Wheel in accordance with the Service Information. Perform ABS VERIFICATION TEST - VER 1.  No → Go To 5	All

**LEFT FRONT WHEEL SPEED SENSOR SIGNAL — Continued**

TEST	ACTION	APPLICABILITY
5	Turn the ignition off. Using a Feeler Gauge, measure the affected Wheel Speed Sensor Air Gap. <b>NOTE: Refer to the appropriate service information, if necessary, for procedures or specifications.</b> Is the Air Gap within specifications?  Yes → Go To 6  No → Repair as necessary. Perform ABS VERIFICATION TEST - VER 1.	All
6	Turn the ignition off. Inspect the wheel bearings for excessive runout or clearance. <b>NOTE: Refer to the appropriate service information, if necessary, for procedures or specifications.</b> Is the wheel bearing clearance within specifications?  Yes → Go To 7  No → Repair as necessary. Perform ABS VERIFICATION TEST - VER 1.	All
7	Turn the ignition off. Visually inspect brakes for locking up due to lining contamination or overheating. Inspect all components for defects which may cause a WHEEL SPEED SENSOR SIGNAL DTC to set. Is any component damaged?  Yes → Repair as necessary. Perform ABS VERIFICATION TEST - VER 1.  No → Refer to symptom WHEEL SPEED SENSOR CIRCUIT for further diagnostics. Perform ABS VERIFICATION TEST - VER 1.	All

**Symptom:**  
**MIC MESSAGES NOT RECEIVED**

**When Monitored and Set Condition:**

**MIC MESSAGES NOT RECEIVED**

When Monitored: Ignition On - Continuously

Set Condition: When the ABM detects the MIC is not connected or not functioning correctly for 10 seconds.

**POSSIBLE CAUSES**

CHECK FOR DTCS  
 VERIFY DTC  
 ATTEMPT TO COMMUNICATE WITH THE MIC  
 MODULE

TEST	ACTION	APPLICABILITY
1	Turn the ignition on. With the DRBIII®, read BCM DTC's. Are any Cluster Wakeup Output DTC's set?  Yes → Refer to symptom list for problems related to the cluster wakeup circuit. Perform BODY VERIFICATION TEST - VER 1.  No → Go To 2	All
2	Turn the ignition on. With the DRBIII®, erase DTC's. With the DRBIII®, read DTC's. Did this DTC reset?  Yes → Go To 3  No → The condition that caused this DTC is currently not present. Use the wiring diagrams/schematic as a guide, and inspect the related wiring harness for a possible intermittent. Perform BODY VERIFICATION TEST - VER 1.	All
3	Turn the ignition on. With the DRBIII®, attempt to communicate with the Instrument Cluster (MIC). Was the DRBIII® able to I/D or communicate with the Instrument Cluster (MIC)?  Yes → Go To 4  No → Refer to the Communication category for the related symptom(s). Perform BODY VERIFICATION TEST - VER 1.	All

**MIC MESSAGES NOT RECEIVED — Continued**

<b>TEST</b>	<b>ACTION</b>	<b>APPLICABILITY</b>
4	With the DRBIII®, erase DTC's. Cycle the ignition switch from off to on and wait approximately 1 minute. With the DRBIII®, read DTC's. Did this DTC reset?  Yes → Replace the module which set the DTC in accordance with the service information. Perform BODY VERIFICATION TEST - VER 1.  No → Test Complete.	All

**Symptom:**  
**PCI BUS COMMUNICATION**

**When Monitored and Set Condition:**

**PCI BUS COMMUNICATION**

When Monitored: Ignition On - Continuously

Set Condition: When the ABM detects PCI Bus not connected or is shorted to voltage or ground.

**POSSIBLE CAUSES**

INTERMITTENT DTC  
 DAMAGED ABM/ABM HARNESS CONNECTOR  
 FUSED RUN RELAY OUTPUT CIRCUIT OPEN  
 ABS VALVE FUSED B(+) CIRCUIT OPEN  
 ABM - GROUND CIRCUIT OPEN  
 PCI BUS CIRCUIT OPEN  
 ABM - INTERNAL FAULT  
 PCI BUS CIRCUIT SHORT TO VOLTAGE  
 PCI BUS CIRCUIT SHORT TO GROUND

TEST	ACTION	APPLICABILITY
1	Turn the ignition on. With the DRBIII®, read DTCs. With the DRBIII®, erase DTCs. Turn the ignition off. Turn the ignition on. With the DRBIII®, read DTCs. Does the DRBIII® display PCI BUS COMMUNICATION?  Yes → Go To 2 No → Go To 9	All
2	Turn the ignition off. Disconnect the ABM harness connector. Inspect the ABM/ABM harness connector for damage. Is there any broken, bent, pushed out, corroded or spread terminals?  Yes → Repair as necessary. Perform ABS VERIFICATION TEST - VER 1.  No → Go To 3	All

**PCI BUS COMMUNICATION — Continued**

TEST	ACTION	APPLICABILITY
3	Turn the ignition off. Disconnect the ABM harness connector. Turn the ignition on. Measure the voltage of the Fused Run Relay Output circuit. Is the voltage above 10 volts?  Yes → Go To 4  No → Repair the Fused Run Relay Output circuit for an open. Perform ABS VERIFICATION TEST - VER 1.	All
4	Turn the ignition off. Disconnect the ABM harness connector. Measure the voltage of the ABS Valve Fused B(+) circuit. Is the voltage above 10 volts?  Yes → Go To 5  No → Repair the ABS Valve Fused B(+) circuit for an open. Perform ABS VERIFICATION TEST - VER 1.	All
5	Turn the ignition off. Disconnect the ABM harness connector. Measure the resistance of the ground circuits. Is the resistance below 5.0 ohms?  Yes → Go To 6  No → Repair the ground circuit(s) for an open. Perform ABS VERIFICATION TEST - VER 1.	All
6	Turn the ignition off. Disconnect the ABM harness connector. Turn the ignition on. Measure the voltage of the PCI Bus circuit. Is there any voltage present?  Yes → Repair the PCI Bus circuit for a short to voltage. Perform ABS VERIFICATION TEST - VER 1.  No → Go To 7	All
7	Turn the ignition off. Disconnect the ABM harness connector. Measure the resistance between ground and the PCI Bus circuit. Is the resistance below 5.0 ohms?  Yes → Repair the PCI Bus circuit for a short to ground. Perform ABS VERIFICATION TEST - VER 1.  No → Go To 8	All

**PCI BUS COMMUNICATION — Continued**

<b>TEST</b>	<b>ACTION</b>	<b>APPLICABILITY</b>
8	Turn the ignition off. Disconnect the ABM harness connector. Measure the resistance of the PCI Bus circuit between the ABM harness connector and the Data Link connector. Is the resistance over 5.0 ohms?  Yes → Repair the PCI Bus circuit for an open. Perform ABS VERIFICATION TEST - VER 1.  No → Replace the Anti-Lock Brake Module in accordance with the Service Information. Perform ABS VERIFICATION TEST - VER 1.	All
9	Turn the ignition off. Visually inspect the related wiring harness. Look for any chafed, pierced, pinched, or partially broken wires. Visually inspect the related wire harness connectors. Look for broken, bent, pushed out, or corroded terminals. Refer to any Hotline letters or Technical Service Bulletins that may apply. Were any problems found?  Yes → Repair as necessary. Perform ABS VERIFICATION TEST - VER 1.  No → Test Complete.	All

**Symptom:**  
**PCI BUS LOOPBACK**

**When Monitored and Set Condition:**

**PCI BUS LOOPBACK**

When Monitored: Ignition On - Continuously

Set Condition: When the ABM detects PCI Bus messages have been missing for 5 seconds and has failed the self test.

**POSSIBLE CAUSES**

INTERMITTENT DTC  
 DAMAGED ABM/ABM HARNESS CONNECTOR  
 FUSED RUN RELAY OUTPUT CIRCUIT OPEN  
 ABS VALVE FUSED B(+) CIRCUIT OPEN  
 ABM - GROUND CIRCUIT OPEN  
 ABM - INTERNAL FAULT

TEST	ACTION	APPLICABILITY
1	Turn the ignition on. With the DRBIII®, read DTCs. With the DRBIII®, erase DTCs. Turn the ignition off. Turn the ignition on. With the DRBIII®, read DTCs. Does the DRBIII® display PCI BUS LOOPBACK?  Yes → Go To 2  No → Go To 6	All
2	Turn the ignition off. Disconnect the ABM harness connector. Inspect the ABM/ABM harness connector for damage. Is there any broken, bent, pushed out, corroded or spread terminals?  Yes → Repair as necessary. Perform ABS VERIFICATION TEST - VER 1.  No → Go To 3	All
3	Turn the ignition off. Disconnect the ABM harness connector. Turn the ignition on. Measure the voltage of the Fused Run Relay Output circuit. Is the voltage above 10 volts?  Yes → Go To 4  No → Repair the Fused Run Relay Output circuit for an open. Perform ABS VERIFICATION TEST - VER 1.	All



**PCI BUS LOOPBACK — Continued**

<b>TEST</b>	<b>ACTION</b>	<b>APPLICABILITY</b>
4	Turn the ignition off. Disconnect the ABM harness connector. Measure the voltage of the ABS Valve Fused B(+) circuit. Is the voltage above 10 volts?  Yes → Go To 5  No → Repair the ABS Valve Fused B(+) circuit for an open. Perform ABS VERIFICATION TEST - VER 1.	All
5	Turn the ignition off. Disconnect the ABM harness connector. Measure the resistance of the ground circuits. Is the resistance below 5.0 ohms?  Yes → Replace the Anti-Lock Brake Module in accordance with the Service Information. Perform ABS VERIFICATION TEST - VER 1.  No → Repair the ground circuit(s) for an open. Perform ABS VERIFICATION TEST - VER 1.	All
6	Turn the ignition off. Visually inspect the related wiring harness. Look for any chafed, pierced, pinched, or partially broken wires. Visually inspect the related wire harness connectors. Look for broken, bent, pushed out, or corroded terminals. Refer to any Hotline letters or Technical Service Bulletins that may apply. Were any problems found?  Yes → Repair as necessary. Perform ABS VERIFICATION TEST - VER 1.  No → Test Complete.	All

**Symptom:**  
**PCI BUS SHORTED TO GROUND**

**When Monitored and Set Condition:**

**PCI BUS SHORTED TO GROUND**

When Monitored: Ignition On - Continuously

Set Condition: When the ABM detects PCI Bus is shorted to ground for more than 10 seconds.

<b>POSSIBLE CAUSES</b>
<p>INTERMITTENT DTC</p> <p>DAMAGED ABM/ABM HARNESS CONNECTOR</p> <p>FUSED RUN RELAY OUTPUT CIRCUIT OPEN</p> <p>ABS VALVE FUSED B(+) CIRCUIT OPEN</p> <p>ABM - GROUND CIRCUIT OPEN</p> <p>PCI BUS CIRCUIT OPEN</p> <p>ABM - INTERNAL FAULT</p> <p>PCI BUS CIRCUIT SHORT TO VOLTAGE</p> <p>PCI BUS CIRCUIT SHORT TO GROUND</p>

<b>TEST</b>	<b>ACTION</b>	<b>APPLICABILITY</b>
1	<p>Turn the ignition on.</p> <p>With the DRBIII®, read DTCs.</p> <p>With the DRBIII®, erase DTCs.</p> <p>Turn the ignition off.</p> <p>Turn the ignition on.</p> <p>With the DRBIII®, read DTCs.</p> <p>Does the DRBIII® display PCI BUS SHORTED TO GROUND?</p> <p style="padding-left: 40px;">Yes → Go To 2</p> <p style="padding-left: 40px;">No → Go To 9</p>	All
2	<p>Turn the ignition off.</p> <p>Disconnect the ABM harness connector.</p> <p>Inspect the ABM/ABM harness connector for damage.</p> <p>Is there any broken, bent, pushed out, corroded or spread terminals?</p> <p style="padding-left: 40px;">Yes → Repair as necessary.</p> <p style="padding-left: 80px;">Perform ABS VERIFICATION TEST - VER 1.</p> <p style="padding-left: 40px;">No → Go To 3</p>	All

**PCI BUS SHORTED TO GROUND — Continued**

TEST	ACTION	APPLICABILITY
3	Turn the ignition off. Disconnect the ABM harness connector. Turn the ignition on. Measure the voltage of the Fused Run Relay Output circuit. Is the voltage above 10 volts?  Yes → Go To 4  No → Repair the Fused Run Relay Output circuit for an open. Perform ABS VERIFICATION TEST - VER 1.	All
4	Turn the ignition off. Disconnect the ABM harness connector. Measure the voltage of the ABS Valve Fused B(+) circuit. Is the voltage above 10 volts?  Yes → Go To 5  No → Repair the ABS Valve Fused B(+) circuit for an open. Perform ABS VERIFICATION TEST - VER 1.	All
5	Turn the ignition off. Disconnect the ABM harness connector. Measure the resistance of the ground circuits. Is the resistance below 5.0 ohms?  Yes → Go To 6  No → Repair the ground circuit(s) for an open. Perform ABS VERIFICATION TEST - VER 1.	All
6	Turn the ignition off. Disconnect the ABM harness connector. Turn the ignition on. Measure the voltage of the PCI Bus circuit. Is there any voltage present?  Yes → Repair the PCI Bus circuit for a short to voltage. Perform ABS VERIFICATION TEST - VER 1.  No → Go To 7	All
7	Turn the ignition off. Disconnect the ABM harness connector. Measure the resistance between ground and the PCI Bus circuit. Is the resistance below 5.0 ohms?  Yes → Repair the PCI Bus circuit for a short to ground. Perform ABS VERIFICATION TEST - VER 1.  No → Go To 8	All

**PCI BUS SHORTED TO GROUND — Continued**

TEST	ACTION	APPLICABILITY
8	<p>Turn the ignition off.                      Disconnect the ABM harness connector.                      Measure the resistance of the PCI Bus circuit between the ABM harness connector and the Data Link connector.                      Is the resistance over 5.0 ohms?</p> <p>Yes → Repair the PCI Bus circuit for an open.                      Perform ABS VERIFICATION TEST - VER 1.</p> <p>No → Replace the Anti-Lock Brake Module in accordance with the Service Information.                      Perform ABS VERIFICATION TEST - VER 1.</p>	All
9	<p>Turn the ignition off.                      Visually inspect the related wiring harness. Look for any chafed, pierced, pinched, or partially broken wires.                      Visually inspect the related wire harness connectors. Look for broken, bent, pushed out, or corroded terminals.                      Refer to any Hotline letters or Technical Service Bulletins that may apply.                      Were any problems found?</p> <p>Yes → Repair as necessary.                      Perform ABS VERIFICATION TEST - VER 1.</p> <p>No → Test Complete.</p>	All

**Symptom:**  
**PCI BUS SHORTED TO VOLTAGE**

**When Monitored and Set Condition:**

**PCI BUS SHORTED TO VOLTAGE**

When Monitored: Ignition On - Continuously

Set Condition: When the ABM detects PCI Bus is shorted to voltage for more than 10 seconds.

**POSSIBLE CAUSES**

INTERMITTENT DTC  
 DAMAGED ABM/ABM HARNESS CONNECTOR  
 FUSED RUN RELAY OUTPUT CIRCUIT OPEN  
 ABS VALVE FUSED B(+) CIRCUIT OPEN  
 ABM - GROUND CIRCUIT OPEN  
 PCI BUS CIRCUIT OPEN  
 ABM - INTERNAL FAULT  
 PCI BUS CIRCUIT SHORT TO VOLTAGE  
 PCI BUS CIRCUIT SHORT TO GROUND

TEST	ACTION	APPLICABILITY
1	Turn the ignition on. With the DRBIII®, read DTCs. With the DRBIII®, erase DTCs. Turn the ignition off. Turn the ignition on. With the DRBIII®, read DTCs. Does the DRBIII® display PCI BUS SHORTED TO VOLTAGE?  Yes → Go To 2 No → Go To 9	All
2	Turn the ignition off. Disconnect the ABM harness connector. Inspect the ABM/ABM harness connector for damage. Is there any broken, bent, pushed out, corroded or spread terminals?  Yes → Repair as necessary. Perform ABS VERIFICATION TEST - VER 1.  No → Go To 3	All

**PCI BUS SHORTED TO VOLTAGE — Continued**

TEST	ACTION	APPLICABILITY
3	Turn the ignition off. Disconnect the ABM harness connector. Turn the ignition on. Measure the voltage of the Fused Run Relay Output circuit. Is the voltage above 10 volts?  Yes → Go To 4  No → Repair the Fused Run Relay Output circuit for an open. Perform ABS VERIFICATION TEST - VER 1.	All
4	Turn the ignition off. Disconnect the ABM harness connector. Measure the voltage of the ABS Valve Fused B(+) circuit. Is the voltage above 10 volts?  Yes → Go To 5  No → Repair the ABS Valve Fused B(+) circuit for an open. Perform ABS VERIFICATION TEST - VER 1.	All
5	Turn the ignition off. Disconnect the ABM harness connector. Measure the resistance of the ground circuits. Is the resistance below 5.0 ohms?  Yes → Go To 6  No → Repair the ground circuit(s) for an open. Perform ABS VERIFICATION TEST - VER 1.	All
6	Turn the ignition off. Disconnect the ABM harness connector. Turn the ignition on. Measure the voltage of the PCI Bus circuit. Is there any voltage present?  Yes → Repair the PCI Bus circuit for a short to voltage. Perform ABS VERIFICATION TEST - VER 1.  No → Go To 7	All
7	Turn the ignition off. Disconnect the ABM harness connector. Measure the resistance between ground and the PCI Bus circuit. Is the resistance below 5.0 ohms?  Yes → Repair the PCI Bus circuit for a short to ground. Perform ABS VERIFICATION TEST - VER 1.  No → Go To 8	All

**PCI BUS SHORTED TO VOLTAGE — Continued**

<b>TEST</b>	<b>ACTION</b>	<b>APPLICABILITY</b>
8	Turn the ignition off. Disconnect the ABM harness connector. Measure the resistance of the PCI Bus circuit between the ABM harness connector and the Data Link connector. Is the resistance over 5.0 ohms?  Yes → Repair the PCI Bus circuit for an open. Perform ABS VERIFICATION TEST - VER 1.  No → Replace the Anti-Lock Brake Module in accordance with the Service Information. Perform ABS VERIFICATION TEST - VER 1.	All
9	Turn the ignition off. Visually inspect the related wiring harness. Look for any chafed, pierced, pinched, or partially broken wires. Visually inspect the related wire harness connectors. Look for broken, bent, pushed out, or corroded terminals. Refer to any Hotline letters or Technical Service Bulletins that may apply. Were any problems found?  Yes → Repair as necessary. Perform ABS VERIFICATION TEST - VER 1.  No → Test Complete.	All

**Symptom:**  
**PCI HARDWARE**

**When Monitored and Set Condition:**

**PCI HARDWARE**

When Monitored: Ignition On - Continuously

Set Condition: When the ABM detects an initialization or configuration failure that doesn't match the programmed parameters.

**POSSIBLE CAUSES**

INTERMITTENT DTC  
 DAMAGED ABM/ABM HARNESS CONNECTOR  
 FUSED RUN RELAY OUTPUT CIRCUIT OPEN  
 ABS VALVE FUSED B(+) CIRCUIT OPEN  
 ABM - GROUND CIRCUIT OPEN  
 ABM - INTERNAL FAULT

TEST	ACTION	APPLICABILITY
1	Turn the ignition on. With the DRBIII®, read DTCs. With the DRBIII®, erase DTCs. Turn the ignition off. Turn the ignition on. With the DRBIII®, read DTCs. Does the DRBIII® display PCI HARDWARE?  Yes → Go To 2  No → Go To 6	All
2	Turn the ignition off. Disconnect the ABM harness connector. Inspect the ABM/ABM harness connector for damage. Is there any broken, bent, pushed out, corroded or spread terminals?  Yes → Repair as necessary. Perform ABS VERIFICATION TEST - VER 1.  No → Go To 3	All
3	Turn the ignition off. Disconnect the ABM harness connector. Turn the ignition on. Measure the voltage of the Fused Run Relay Output circuit. Is the voltage above 10 volts?  Yes → Go To 4  No → Repair the Fused Run Relay Output circuit for an open. Perform ABS VERIFICATION TEST - VER 1.	All



**PCI HARDWARE — Continued**

<b>TEST</b>	<b>ACTION</b>	<b>APPLICABILITY</b>
4	Turn the ignition off. Disconnect the ABM harness connector. Measure the voltage of the ABS Valve Fused B(+) circuit. Is the voltage above 10 volts?  Yes → Go To 5  No → Repair the ABS Valve Fused B(+) circuit for an open. Perform ABS VERIFICATION TEST - VER 1.	All
5	Turn the ignition off. Disconnect the ABM harness connector. Measure the resistance of the ground circuits. Is the resistance below 5.0 ohms?  Yes → Replace the Anti-Lock Brake Module in accordance with the Service Information. Perform ABS VERIFICATION TEST - VER 1.  No → Repair the ground circuit(s) for an open. Perform ABS VERIFICATION TEST - VER 1.	All
6	Turn the ignition off. Visually inspect the related wiring harness. Look for any chafed, pierced, pinched, or partially broken wires. Visually inspect the related wire harness connectors. Look for broken, bent, pushed out, or corroded terminals. Refer to any Hotline letters or Technical Service Bulletins that may apply. Were any problems found?  Yes → Repair as necessary. Perform ABS VERIFICATION TEST - VER 1.  No → Test Complete.	All

**Symptom:**  
**PCM MESSAGES NOT RECEIVED**

**When Monitored and Set Condition:**

**PCM MESSAGES NOT RECEIVED**

When Monitored: Ignition On - Continuously

Set Condition: When the ABM detects the PCM is not connected or not functioning correctly for 10 seconds.

**POSSIBLE CAUSES**

PCM MESSAGES NOT RECEIVED  
 ATTEMPT TO COMMUNICATE WITH THE PCM  
 PCI BUS CIRCUIT OPEN  
 POWERTRAIN CONTROL MODULE

TEST	ACTION	APPLICABILITY
1	Turn the ignition on. With the DRBIII®, enter Instrument Cluster, System Tests then PCM Monitor. Does the DRBIII® display: PCM is active on BUS?  Yes → Erase the DTC, if DTC resets, measure the resistance of the PCI Bus circuit between the PCM connector and the ABM connector. If open, repair as necessary. Perform BODY VERIFICATION TEST - VER 1.  No → Go To 2	All
2	Turn the ignition on. With the DRBIII®, attempt to communicate with the PCM. Was the DRBIII® able to communicate with the PCM?  Yes → Go To 3  No → Refer to the communication category and perform the appropriate symptom. Perform BODY VERIFICATION TEST - VER 1.	All

**PCM MESSAGES NOT RECEIVED — Continued**

TEST	ACTION	APPLICABILITY
3	Turn the ignition off. Disconnect the PCM harness connector. <b>CAUTION: DO NOT PROBE THE PCM HARNESS CONNECTORS. PROBING THE PCM HARNESS CONNECTORS WILL DAMAGE THE PCM TERMINALS RESULTING IN POOR TERMINAL TO PIN CONNECTION. INSTALL MILLER SPECIAL TOOL #8815 TO PERFORM DIAGNOSIS.</b> Measure the resistance of the PCI Bus circuit between the DLC and the PCM connector. Is the resistance below 5.0 ohms?  Yes → Replace and program the Powertrain Control Module in accordance with the Service Information. Perform BODY VERIFICATION TEST - VER 1.  No → Repair the PCI Bus circuit for an open. Perform BODY VERIFICATION TEST - VER 1.	All

**Symptom:**  
**PUMP MOTOR CIRCUIT**

**When Monitored and Set Condition:**

**PUMP MOTOR CIRCUIT**

When Monitored: Ignition On - Continuously

Set Condition: When the ABM detects the pump motor voltage is too low or high when pump motor is enabled or disabled. The pump motor fails the slow down test after the end of a pump motor event.

**POSSIBLE CAUSES**

INTERMITTENT DTC  
 DAMAGED ABM/ABM HARNESS CONNECTOR  
 ABS PUMP FUSED B(+) CIRCUIT OPEN  
 PUMP MOTOR GROUND CIRCUITS OPEN  
 ABM - INTERNAL FAULT

TEST	ACTION	APPLICABILITY
1	Turn the ignition off. Turn the ignition on. With the DRBIII®, read DTCs. With the DRBIII®, erase DTCs. Turn the ignition off. Turn the ignition on. With the DRBIII®, read DTCs. Does the DRBIII® display PUMP MOTOR CIRCUIT?  Yes → Go To 4  No → Go To 2	All
2	Turn the ignition off. Turn the ignition on. With the DRBIII®, actuate the Pump. Did the Pump operate?  Yes → Go To 3  No → Go To 4	All

**PUMP MOTOR CIRCUIT — Continued**

TEST	ACTION	APPLICABILITY
3	Turn the ignition off. Visually inspect the related wiring harness. Look for any chafed, pierced, pinched, or partially broken wires. Make sure the ABM harness connector is secure. Visually inspect the related wire harness connectors. Look for broken, bent, pushed out, or corroded terminals. Refer to any Hotline letters or Technical Service Bulletins that may apply. Were any problems found?  Yes → Repair as necessary. Perform ABS VERIFICATION TEST - VER 1.  No → Test Complete.	All
4	Turn the ignition off. Disconnect the ABM harness connector. Inspect the ABM and ABM harness connector for damage. Is there any broken, bent, pushed out, corroded, or spread terminals?  Yes → Repair as necessary. Perform ABS VERIFICATION TEST - VER 1.  No → Go To 5	All
5	Turn the ignition off. Disconnect the ABM harness connector. Check connectors - Clean/repair as necessary. Measure the voltage of the ABS Pump Fused B(+) circuit. Is the voltage above 10 volts?  Yes → Go To 6  No → Repair the ABS Pump Fused B(+) circuit for an open. Perform ABS VERIFICATION TEST - VER 1.	All
6	Turn the ignition off. Disconnect the ABM harness connector. Check connectors - Clean/repair as necessary. Measure the resistance of the ground circuits. Is the resistance below 5.0 ohms?  Yes → Replace the Anti-Lock Brake Module in accordance with the Service Information. Perform ABS VERIFICATION TEST - VER 1.  No → Repair the Pump Motor ground circuit(s) for an open. Perform ABS VERIFICATION TEST - VER 1.	All

**Symptom:**  
**TCM MESSAGES NOT RECEIVED**

**When Monitored and Set Condition:**

**TCM MESSAGES NOT RECEIVED**

When Monitored: Ignition On - Continuously

Set Condition: When the ABM detects the TCM is not connected or not functioning correctly for 10 seconds.

**POSSIBLE CAUSES**

ATTEMPT TO COMMUNICATE WITH THE TCM  
 TRANSMISSION CONTROL MODULE

TEST	ACTION	APPLICABILITY
1	Turn the ignition on. With the DRB, enter Transmission. Was the DRB able to I/D or communicate with the TCM?  Yes → Go To 2  No → Refer to the Communication category for the related symptom(s). Perform BODY VERIFICATION TEST - VER 1.	All
2	With the DRB, erase DTC's. Turn the ignition on and wait approximately 1 minute. With the DRB, read DTC's. Did this DTC reset?  Yes → Replace the Transmission Control Module in accordance with the service information. Perform BODY VERIFICATION TEST - VER 1.  No → Test Complete.	All

**Verification Tests**

ABS VERIFICATION TEST - VER 1	APPLICABILITY
<p>1. Turn the ignition off.</p> <p>2. Connect all previously disconnected components and connectors.</p> <p>3. Ensure all accessories are turned off and the battery is fully charged.</p> <p>4. Ensure that the Ignition is on, and with the DRBIII, erase all Diagnostic Trouble Codes from ALL modules. Start the engine and allow it to run for 2 minutes and fully operate the system that was malfunctioning.</p> <p>5. Turn the ignition off and wait 5 seconds. Turn the ignition on and using the DRBIII®, read DTC's from ALL modules.</p> <p>6. If any Diagnostic Trouble Codes are present, return to Symptom list and troubleshoot new or recurring symptom.</p> <p><b>7. NOTE: For Sensor Signal and Pump Motor faults, the ABM must sense all 4 wheels at 25 km/h (15 mph) before it will extinguish the ABS Indicator.</b></p> <p>8. If there are no DTC's present after turning ignition on, road test the vehicle for at least 5 minutes. Perform several anti-lock braking stops.</p> <p><b>9. Caution: Ensure braking capability is available before road testing.</b></p> <p>10. Again, with the DRBIII® read DTC's. If any DTC's are present, return to Symptom list.</p> <p>11. If there are no Diagnostic Trouble Codes (DTC's) present, and the customer's concern can no longer be duplicated, the repair is complete.</p> <p>Are any DTC's present or is the original concern still present?</p> <p>Yes → Repair is not complete, refer to appropriate symptom.</p> <p>No → Repair is complete.</p>	<p>All</p>

BODY VERIFICATION TEST - VER 1	APPLICABILITY
<p>1. Disconnect all jumper wires and reconnect all previously disconnected components and connectors.</p> <p><b>2. NOTE: If the SKREEM or PCM was replaced, refer to the service information for proper programming procedures. If the IPM was replaced, ensure the IOD fuse is in the Normal Run position.</b></p> <p>3. If the Body Control Module (BCM) was replaced, turn the ignition on for 15 seconds (to allow the new BCM to learn VIN) or engine may not start (if VTSS equipped). If the vehicle is equipped with VTSS, use the DRBIII® and enable VTSS.</p> <p>4. If the Driver or Passenger Door Module was replaced, program the new module by turning the ignition On for 15 seconds and then operate the following switches if equipped: Adjustable Pedals, Heated Seat, Power Seat/Lumbar and Memory Set/Recall.</p> <p>5. Program options as necessary.</p> <p>6. If any repairs were made to the power liftgate, use the DRBIII® and perform the open and close system tests. Observe the instructions on the DRBIII® screen.</p> <p>7. Ensure that all accessories are turned off and the battery is fully charged.</p> <p>8. For MTC HVAC systems, if any HVAC door actuator circuits were repaired, with the DRBIII® in HVAC, select System Tests and run the Actuator Circuit Test.</p> <p>9. For MTC HVAC systems, if any HVAC door actuators were replaced, with the DRBIII® in HVAC, select System Tests and run the HVAC Door Recalibration Test.</p> <p>10. With the DRBIII®, record and erase all DTCs from ALL modules. Start and run the engine for 2 minutes. Operate all functions of the system that caused the original concern.</p> <p>11. Turn the ignition off and wait 5 seconds. Turn the ignition on and using the DRBIII®, read DTCs from ALL modules.</p> <p>Are any DTC's present or is the original condition still present?</p> <p>Yes → Repair is not complete, refer to the appropriate symptom.</p> <p>No → Repair is complete.</p>	<p>All</p>





8.0 COMPONENT LOCATIONS

8.1 DATA LINK CONNECTOR

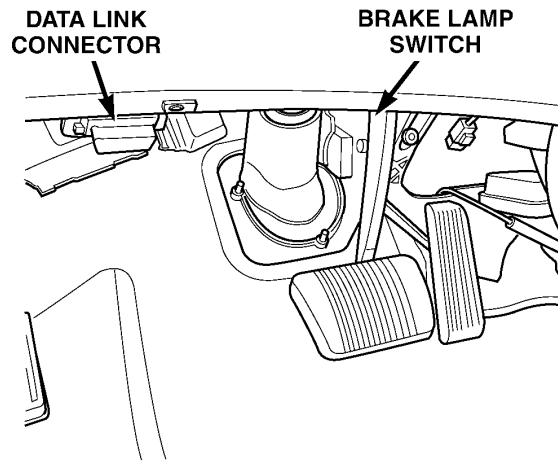

8111593a

8.2 FUSES

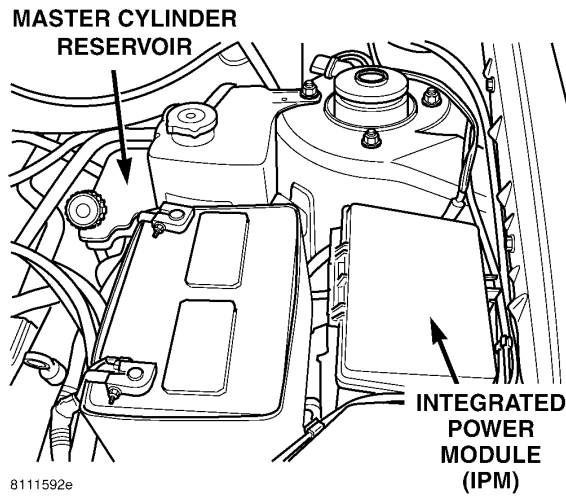

8111592e

8.3 TRACTION CONTROL SWITCH

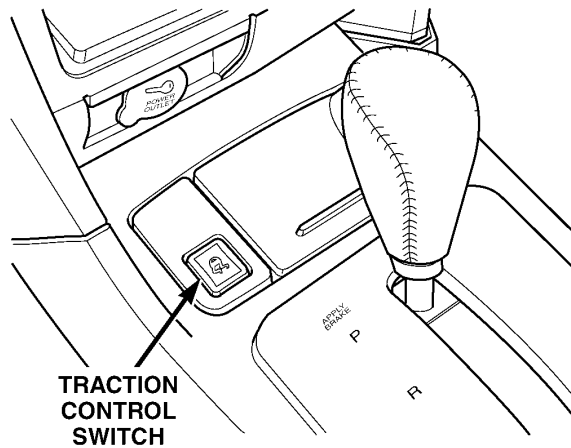

81115936

# COMPONENT LOCATIONS

## 8.4 INDICATORS

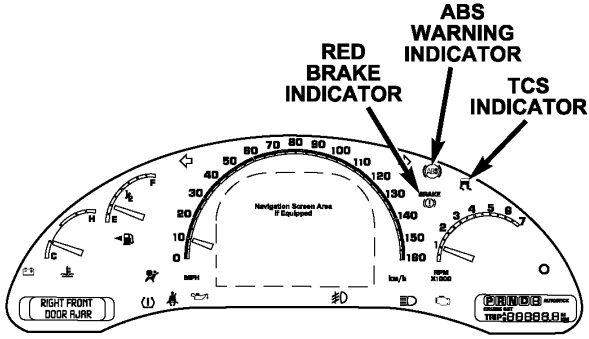

81115921

## 8.5 BRAKE LAMP SWITCH

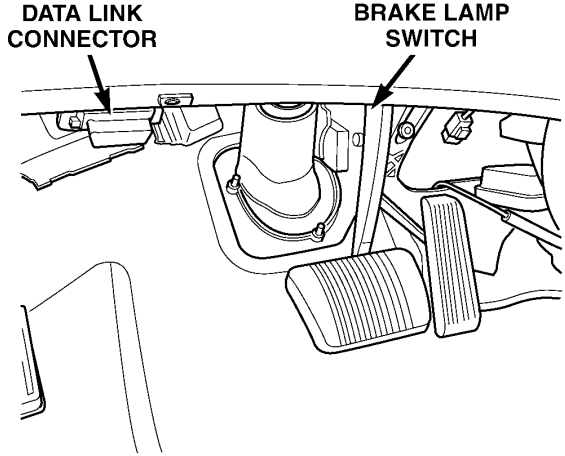

8111593a

## 9.0 CONNECTOR PINOUTS

ANTI-LOCK BRAKE MODULE - BLACK 47 WAY

CAV	CIRCUIT	FUNCTION
1	A107 12TN/RD	FUSED B(+) (PUMP)
2	-	-
3	-	-
4	-	-
5	-	-
6	L51 18WT/DG	BRAKE LAMP SWITCH OUTPUT
7	-	-
8	F500 18DG/PK	FUSED RUN RELAY OUTPUT
9	-	-
10	D24 20WT/YL	FLASH ABS
11	D25 20WT/VT	PCI BUS
12	-	-
13	-	-
14	-	-
15	-	-
16	Z127 12BK/DG	GROUND
17	-	-
18	-	-
19	-	-
20	-	-
21	-	-
22	-	-
23	-	-
24	-	-
25	-	-
26	-	-
27	-	-
28	-	-
29	-	-
30	-	-
31	-	-
32	A111 12DG/RD	FUSED B(+) (VALVE)
33	B6 18DG/WT	RIGHT FRONT WHEEL SPEED SENSOR SIGNAL
34	B7 18DG/VT	RIGHT FRONT WHEEL SPEED SENSOR 12 VOLT SUPPLY
35	-	-
36	B4 18DG/GY	LEFT REAR WHEEL SPEED SENSOR 12 VOLT SUPPLY
37	B3 18DG/YL	LEFT REAR WHEEL SPEED SENSOR SIGNAL
38	-	-
39	-	-
40	-	-
41	-	-
42	B1 18DG/DB	RIGHT REAR WHEEL SPEED SENSOR SIGNAL
43	B2 18DG/LB	RIGHT REAR WHEEL SPEED SENSOR 12 VOLT SUPPLY
44	-	-
45	B9 18DG/LG	LEFT FRONT WHEEL SPEED SENSOR 12 VOLT SUPPLY
46	B8 18DG/TN	LEFT FRONT WHEEL SPEED SENSOR SIGNAL
47	Z107 12BK/LB	GROUND

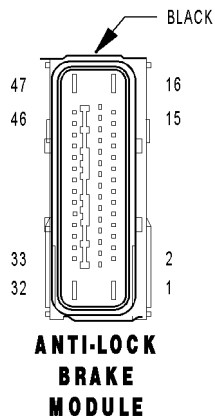

# CONNECTOR PINOUTS

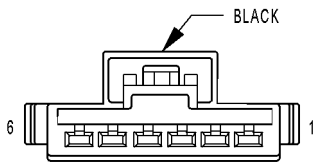

**BRAKE  
LAMP  
SWITCH**

**BRAKE LAMP SWITCH - BLACK 6 WAY**

CAV	CIRCUIT	FUNCTION
1	L51 18WT/DG	BRAKE LAMP SWITCH OUTPUT
2	A108 18LG/RD	FUSED B(+)
3	V30 20VT/WT	SPEED CONTROL BRAKE SWITCH OUTPUT
4	V32 20VT/YL	S/C SUPPLY
5	Z429 20BK/OR	GROUND
6	B29 20DG/WT	BRAKE SWITCH SIGNAL

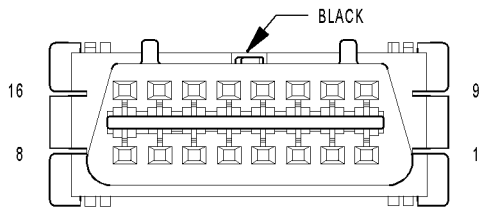

**DATA  
LINK  
CONNECTOR**

**DATA LINK CONNECTOR - BLACK 16 WAY**

CAV	CIRCUIT	FUNCTION
1	-	-
2	D25 20WT/VT	PCI BUS
3	-	-
4	Z11 18BK/LG	GROUND
5	Z111 18BK/WT	GROUND
6	-	-
7	D21 20WT/GY	SCI TRANSMIT (PCM)
8	-	-
9	D123 20WT/BR	FLASH PROGRAM ENABLE
10	D24 20WT/YL	FLASH ABS
11	-	-
12	D20 20WT/LG	SCI RECEIVE (PCM)
13	-	-
14	-	-
15	D15 20BR/WT	SCI TRANSMIT (TCM)
16	A105 20DB/RD	FUSED B(+)

INTEGRATED POWER MODULE  
(FRONT VIEW)

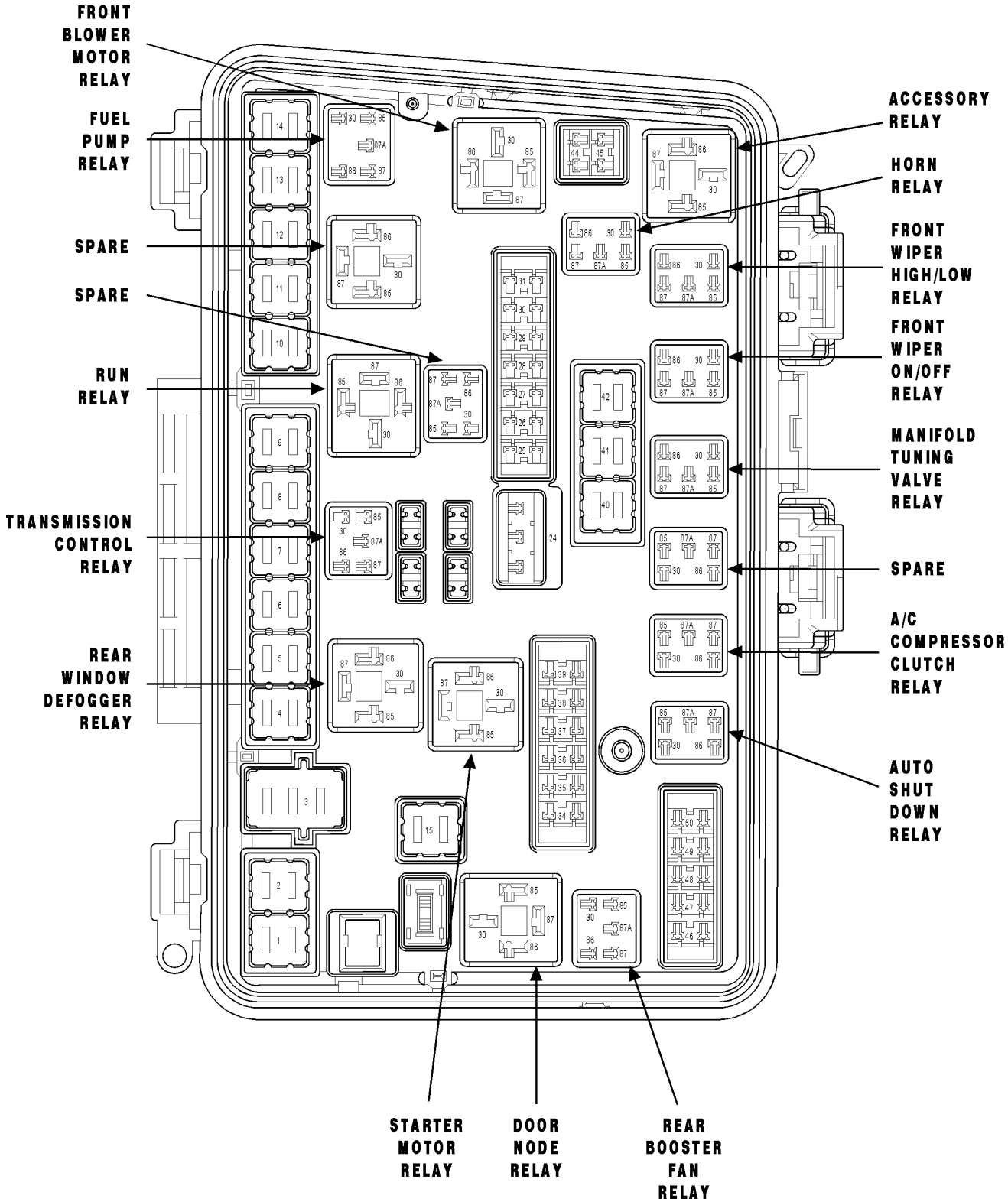

CONNECTOR PINOUTS

# CONNECTOR PINOUTS

## FUSES (IPM)

FUSE NO.	AMPS	FUSED CIRCUIT	FUNCTION
1	40A	A107 12TN/RD	FUSED B(+)
2	-	-	-
3	30A	INTERNAL	FUSED B(+) (I.O.D.)
4	40A	A101 12VT/RD	FUSED B(+)
5	40A	INTERNAL	FUSED B(+)
6	30A	INTERNAL	FUSED B(+)
7	40A	INTERNAL	FUSED B(+)
8	40A	A110 12DG/RD	FUSED B(+)
9	40A	A130 12VT/RD (POWER SUNROOF)	FUSED B(+)
10	30A	A100 16RD/VT (TRAILER TOW)	FUSED B(+)
11	40A	A115 12YL/RD (POWER LIFTGATE)	FUSED B(+)
12	-	-	-
13	40A	A112 12OR/RD	FUSED B(+)
14	-	-	-
15	40A	A111 12DG/RD	FUSED B(+)
24	20A	F307 16LB/PK	FUSED ACCESSORY RELAY OUTPUT
25	15A	F316 20PK/OR	FUSED ACCESSORY RELAY OUTPUT
26	20A	F306 16DB/PK	FUSED ACCESSORY RELAY OUTPUT
27	-	-	-
28	25A	INTERNAL	FUSED B(+)
29	20A	A108 18LG/RD	FUSED B(+)
30	10A	A106 20LB/RD	FUSED B(+)
31	20A	A701 18BR/RD	FUSED B(+)
34	10A	C51 18LB/BR	FUSED REAR BOOSTER FAN RELAY OUTPUT
35	-	-	-
36	20A	INTERNAL	FUSED B(+)
37	25A	INTERNAL	FUSED B(+)
38	20A	INTERNAL	FUSED B(+)
39	20A	A109 18OR/RD	FUSED B(+)
40	40A	F515 12PK/LB	FUSED DOOR NODE RELAY OUTPUT
41	40A	F516 12PK	FUSED DOOR NODE RELAY OUTPUT
42	40A	C7 12DB	FUSED FRONT BLOWER MOTOR RELAY OUTPUT
44	25A	F525 16TN/PK (MIDDLE ROW HEATED SEATS)	FUSED RUN RELAY OUTPUT
45	10A	INTERNAL	FUSED RUN RELAY OUTPUT
46	20A	A214 18RD/LB	FUSED B(+)
47	20A	A215 18RD/LG	FUSED B(+)
48	15A	A114 20GY/RD	FUSED B(+)
49	25A	A116 16YL/RD	FUSED B(+)
50	15A	A118 20RD/OR	FUSED B(+)

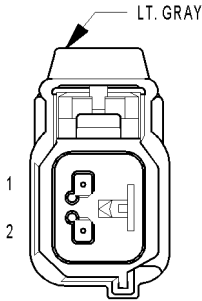

**WHEEL SPEED SENSOR-LEFT FRONT**

**WHEEL SPEED SENSOR-LEFT FRONT - LT. GRAY 2 WAY**

CAV	CIRCUIT	FUNCTION
1	B9 18DG/LG	LEFT FRONT WHEEL SPEED SENSOR 12 VOLT SUPPLY
2	B8 18DG/TN	LEFT FRONT WHEEL SPEED SENSOR SIGNAL

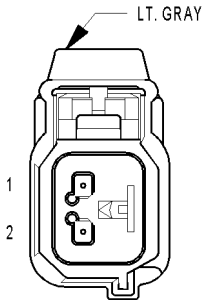

**WHEEL SPEED SENSOR-LEFT REAR**

**WHEEL SPEED SENSOR-LEFT REAR - LT. GRAY 2 WAY**

CAV	CIRCUIT	FUNCTION
1	B4 18DG/GY	LEFT REAR WHEEL SPEED SENSOR 12 VOLT SUPPLY
2	B3 18DG/YL	LEFT REAR WHEEL SPEED SENSOR SIGNAL

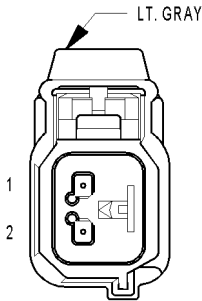

**WHEEL SPEED SENSOR-RIGHT FRONT**

**WHEEL SPEED SENSOR-RIGHT FRONT - LT. GRAY 2 WAY**

CAV	CIRCUIT	FUNCTION
1	B7 18DG/VT	RIGHT FRONT WHEEL SPEED SENSOR 12 VOLT SUPPLY
2	B6 18DG/WT	RIGHT FRONT WHEEL SPEED SENSOR SIGNAL

CONNECTOR PINOUTS

# CONNECTOR PINOUTS

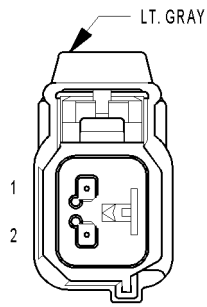

**WHEEL  
SPEED  
SENSOR-  
RIGHT  
REAR**

**WHEEL SPEED SENSOR-RIGHT REAR - LT. GRAY 2 WAY**

CAV	CIRCUIT	FUNCTION
1	B2 18DG/LB	RIGHT REAR WHEEL SPEED SENSOR 12 VOLT SUPPLY
2	B1 18DG/DB	RIGHT REAR WHEEL SPEED SENSOR SIGNAL



10.0 SCHEMATIC DIAGRAMS

10.1 TEVES MARK 25e ANTI-LOCK BRAKE MODULE

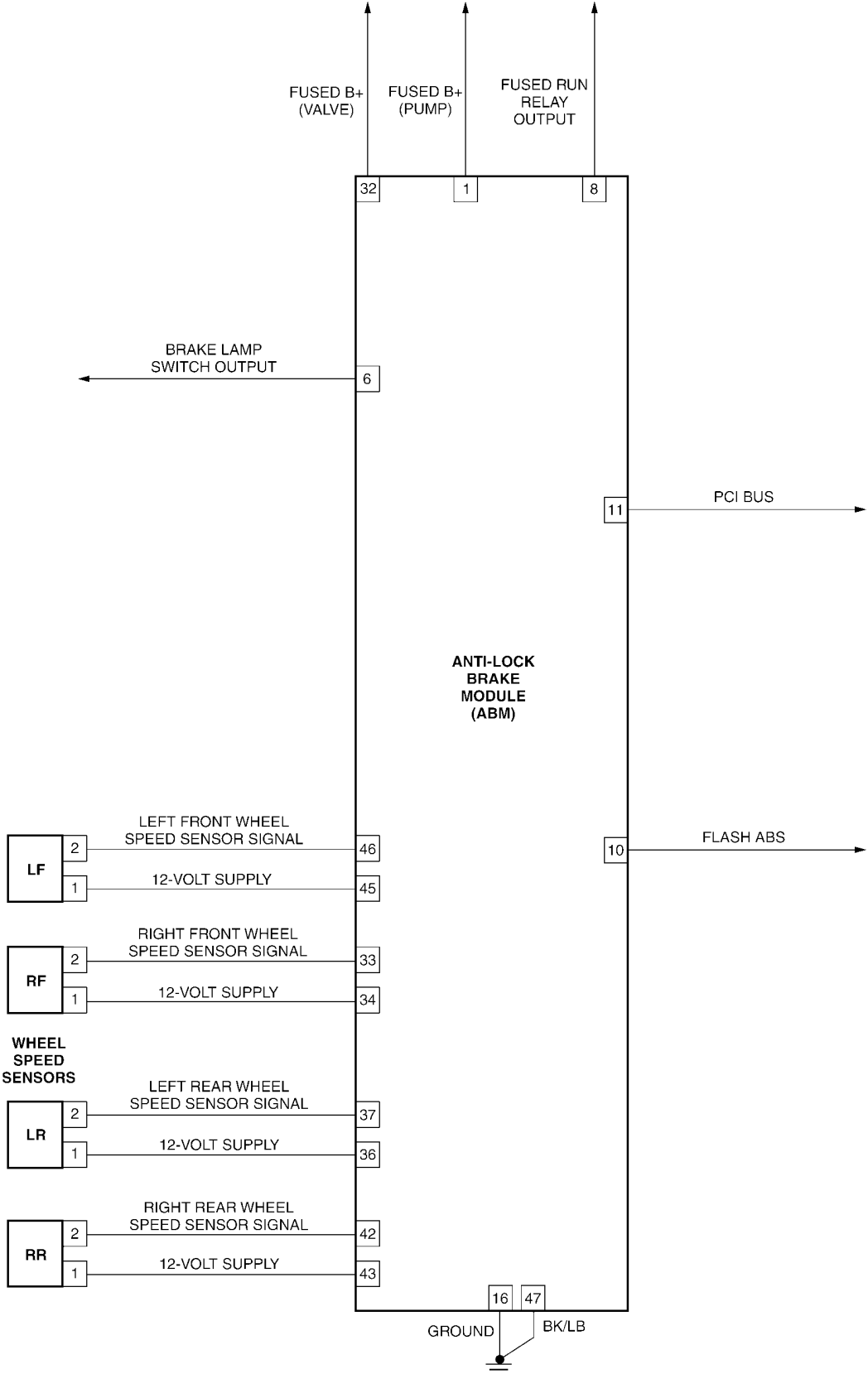

814d9001



## DIAGNOSTIC TEST PROCEDURES — TELL US!

DaimlerChrysler Corporation is constantly working to provide the technician the best diagnostic manuals possible. Your comments and recommendations regarding the diagnostic manuals and procedures are appreciated.

To best understand your suggestion, please complete the form giving us as much detail as possible.

---

**Model** \_\_\_\_\_ **Year** \_\_\_\_\_ **Body Type** \_\_\_\_\_ **Engine** \_\_\_\_\_

**Transmission** \_\_\_\_\_ **Vehicle Mileage** \_\_\_\_\_ **MDH** \_\_\_\_\_

**Diagnostic Procedure** \_\_\_\_\_ **Book No.** \_\_\_\_\_ **Page** \_\_\_\_\_

Comments/recommendations (if necessary, draw sketch)

Name \_\_\_\_\_

Submitted by: \_\_\_\_\_

Address \_\_\_\_\_

City/State/Zip \_\_\_\_\_

Business Phone # \_\_\_\_\_

All comments become property of DaimlerChrysler Corporation and may be used without compensation.

(FOLD HERE)



**BUSINESS REPLY MAIL**  
FIRST CLASS MAIL PERMIT NO. 124 CENTER LINE, MI

POSTAGE WILL BE PAID BY ADDRESSEE

**DaimlerChrysler Corporation**  
Dealer Technical Operations  
800 Chrysler Drive  
CIMS 486-02-76  
Auburn Hills, MI 48326-2757

NO POSTAGE  
NECESSARY  
IF MAILED  
IN THE  
UNITED  
STATES

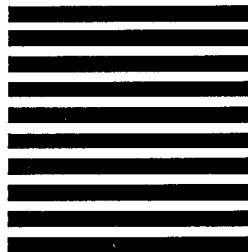

(FOLD HERE)